



User manual



[i-team Professional b.v.](http://www.i-teamglobal.com)

[Hoppenkuil 27b, 5626 DD Eindhoven, The Netherlands](http://www.i-teamglobal.com)

Telephone: +31402662400

Email: hello@i-teamglobal.com

Internet: www.i-teamglobal.com





FASTER:

It takes less than 1 minute to put the i-walk to work which saves time for other tasks. The i-walk handles the movement, allowing operators to focus on more detailed cleaning or customer service, speeding up the overall cleaning process.



CLEANER:

i-walk offers co-botization combined with the i-mop cleaning performance. No compromise on cleaning quality – combine the superior cleaning power of the i-mop with the efficiency of robotics.



GREENER:

Uses 70% less water and chemicals compared to manual cleaning, thanks to its advanced recovery system. Maintains the eco-friendly benefits of the i-mop, ensuring efficient use of water and energy.



SAFER:

Super dry floor reduces slip accidents because of the advanced suction technology. Equipped with multiple sensors to safely navigate around people and objects, reducing the risk of accidents.



...and BETTER for everyone!

Improves the lives of cleaners by doing the repetitive work. Eliminates operator strain completely, as there's no need to manually guide the machine, making cleaning less labor-intensive.

Original user manual, written in the English Language

Future Cleaning Technologies B.V.

Hoppenkuil 27b, 5626 DD Eindhoven, The Netherlands

Telephone: +31402662400

Email: hello@i-teamglobal.com

Internet: www.i-teamglobal.com

Model: i-walk

Date: 11/2024

Product code: IWALK.FCT.0000C

Version: v1.0

Model year: 2024



Preface

Thank you for choosing the i-walk, the co-botic device that cleans faster, cleaner, safer, greener, and is better for everyone. The i-walk compact design allows you to clean right to any edge, minimizing manual scrubbing. The battery-operated i-walk in combination with an i-mop XL provides a deep scrub and a great cleaning result. The i-walk significantly reduces the amount of chemicals needed, which leads to a greener result. It also reduces the risk of slippery floors. The i-walk is coated to withstand abrasive chemicals. This means it can be used at facilities like swimming pools.

Please read this manual carefully for important information and operating instructions before using the i-walk. Save this manual for future reference. This i-walk will provide excellent performance. The best results are obtained when the i-walk is:

- Regularly maintained per the i-walk preventive maintenance instructions in this manual.
- Operated with reasonable care and caution.
- Maintained with manufacturer-supplied parts.

When this manual refers to “the manufacturer”, this means **Future Cleaning Technologies B.V.**, an affiliate company of i-team in Eindhoven, The Netherlands. When this manual mentions “the partner”, this refers to your local i-team resell and support service partner.

Purpose of the user manual

The purpose of the user manual is to provide the user with information in such a way that during the lifespan of the i-walk, the machine is used correctly, efficiently and safely, even in the event of reasonably foreseeable misuse, as described in section 1.2 of this manual.

The user manual contains instructions regarding:

- personal operator safety;
- intended and non-intended use of the i-walk;
- instructions for daily use;
- maintenance instructions;
- storage conditions;
- disposal of the i-walk.

These instructions must be considered to avoid risks that could lead to physical and/or material damage.

Target audience

This user manual is intended for operators of the i-walk and their supervisors, as well as partners and importers.







Operators of the i-walk

The i-walk may only be operated by a person who has correctly read and understood the instructions in this manual or is trained by an experienced operator who has read and understood the instructions in this manual.

Reading guide

The following symbols and terms are used throughout this manual to alert the reader to safety issues and important information:

Symbol	Term	Explanation
	WARNING	Indicates a hazardous situation which, if the safety instructions are not followed, can lead to injuries of the operator or bystanders, light and/or moderate damage to the product or the environment.
	CAUTION	Indicates a hazardous situation which, if the safety instructions are not followed, can lead to light and / or moderate damage to the product or the environment.
	ATTENTION	Indicates a liability situation, where the manufacturer or its partners and affiliates cannot be held accountable for damages caused by non-compliance.
	BATTERIES	Indicates a battery-operated machine, batteries must be charged according to the instructions in the separate class I battery charger user manual. Batteries must be disposed of according to your local laws and regulations.
	SLIPPERY SURFACE	Indicates that the machine can cause floors to become slippery. In the workplace, it is advised to place slippery surface signs in these areas.



Content

Preface	3
Purpose of the user manual	3
Target audience.....	3
Operators of the i-walk	4
Reading guide	4
Content.....	5
1 Introduction	8
1.1 Intended use of the product	8
1.2 Non-intended use of the product.....	9
1.3 Lifespan	9
1.4 Modifications	9
1.5 Specifications	10
1.6 Warranty.....	10
1.7 Identification	11
2 Description	12
2.1 Remote control.....	13
2.2 Handle controller.....	13
2.3 Main menu of the i-walk app.....	14
3 Safety.....	15
3.1 General safety instructions	15
3.1.1 Sweep before scrub	15
3.1.2 Machine orientation	15
3.1.3 Batteries.....	15
3.1.4 i-mop XL safety	15
3.2 Risks during operation.....	15
3.2.1 Radio interference	15
3.2.2 Transparent materials	15
3.2.3 Mark the job site	16
3.3 Risks after operation	16
3.3.1 Remove the battery	16
3.3.2 Careful when storing	16
4 Transport and storage	17
4.1 General	17
4.2 Store position	17



4.3	Transport inside/outside	17
4.4	Transport in a vehicle.....	18
5	Assembly and installation.....	19
5.1	Unboxing.....	19
5.2	Assembly.....	20
5.2.1	Charging the battery	20
5.2.2	Inserting the batteries.....	20
5.2.3	Charging the remote control battery.....	21
5.2.4	Preparing the i-mop XL.....	21
5.2.5	Installing the trolley handles (optional)	23
5.2.6	Connecting the i-walk to the i-mop XL	23
6	Operation	25
6.1	Before you start.....	25
6.2	Setting up the i-walk.....	25
6.2.1	Powering-on and unlocking the i-walk	25
6.2.2	Placing the QR code block.....	26
6.2.3	Connecting the i-walk to the network (optional)	26
6.2.4	Turning on and connecting the remote control.	26
6.3	Auto Fill mode	27
6.3.1	Auto Fill with QR code.....	27
6.4	Teach Repeat mode (with QR code)	28
6.5	Using the i-walk app.....	29
6.5.1	Overview.....	30
6.5.2	Site info.....	31
6.5.3	Machine overview	31
6.5.4	Machine menu	32
6.5.5	Notification menu	35
6.5.6	Notification view	36
6.6	Deleting a cleaning path.....	36
6.7	Emptying and filling water tanks	36
6.8	Pausing the i-walk	37
6.9	Cancelling a cleaning task	37
6.10	Emergency stop	38
6.11	Shutting down the i-walk	39
6.12	Linking/resetting the handle controller.....	40
6.13	Cleaning	41
6.13.1	Removing the battery	41
7	Maintenance	42
7.1	Daily maintenance.....	42
7.2	Two-weekly maintenance	42



7.3	Recommended additional cleaning.....	42
7.4	Recommend service time	42
8	Troubleshooting	42
8.1	Problems.....	43
8.2	Fault problems.....	43
9	Decommissioning and disposal	45
10	Attachments	46
10.1	CE Certificate.....	46
10.2	Specifications	47
10.3	The i-Story.....	48



1 Introduction

The i-walk is a safe, user-friendly machine. This manual helps you to get started and explains the setup, operation and maintenance procedure. You will be pleasantly surprised by the fast and effective use of the battery-operated i-walk. The battery used in the i-walk comes from the same family as the ones used in a variety of battery-powered i-team products. The battery must be fully charged before use. Please see the user manual of the battery charger for the correct procedure.

This manual is intended for those who work with the i-walk and/or perform daily maintenance. The manual must be read fully before starting to work with the machine. This manual describes the correct method of use, safety measures, maintenance, and transport.

The manufacturer continuously improves all its products based on user experience and feedback. Any deviations between the texts and/or images from the manual and your i-walk can therefore arise from the difference in model, or from possible changes due to continuous development and innovation.

1.1 Intended use of the product

The i-walk is a machine that connects with the i-mop XL to combine the unequalled cleaning results of the i-mop XL with powerful and modern co-botic technology.



Figure 1



1.2 Non-intended use of the product



WARNING

Non-intended use can have consequences for the safety of operators and bystanders and will void the warranty on the product.

- **DO NOT** use the i-walk in areas above a sea level of 2000 m.
- **DO NOT** use or park this product in a pure-slope place with a slope angle greater than 5°.
- **DO NOT** use this product in an environment with a temperature higher than 40 °C and lower than 0 °C.
- **DO NOT** wash or spray the i-walk with water.
- **DO NOT** place any objects (including children and pets) on the static or moving i-walk body.
- **DO NOT** use this product to clean
 - any burning objects (such as burning cigarette butts),
 - any hard objects,
 - any sharp objects (such as decoration wastes, glass and nails).
- **DO NOT** use this product on
 - soil surfaces,
 - grasses,
 - artificial turfs,
 - carpeted floors.
- **DO NOT** use this product in case of rough surface conditions, such as uneven ground or ground with large potholes. Bypass these dangerous areas when planning a path.
- **DO NOT** deploy and use this product in humid environments. Excessive humid environments may cause damage to electronic circuits or electronic components in this product.
- **DO NOT** approach the i-walk suddenly or block the i-walk. Prevent both people and pets from doing this to avoid collision and damage.

1.3 Lifespan

Each i-walk is guaranteed to operate for at least 2000 hours.



CAUTION

To ensure proper and safe operation throughout the life of the i-walk, the machine must be checked by an authorized i-team partner every 10,000 hours.

1.4 Modifications

It is not permitted to make modifications to the design of the i-walk without consultation and permission from the manufacturer. Doing so affects the warranty, see section 1.6 of this manual.



1.5 Specifications

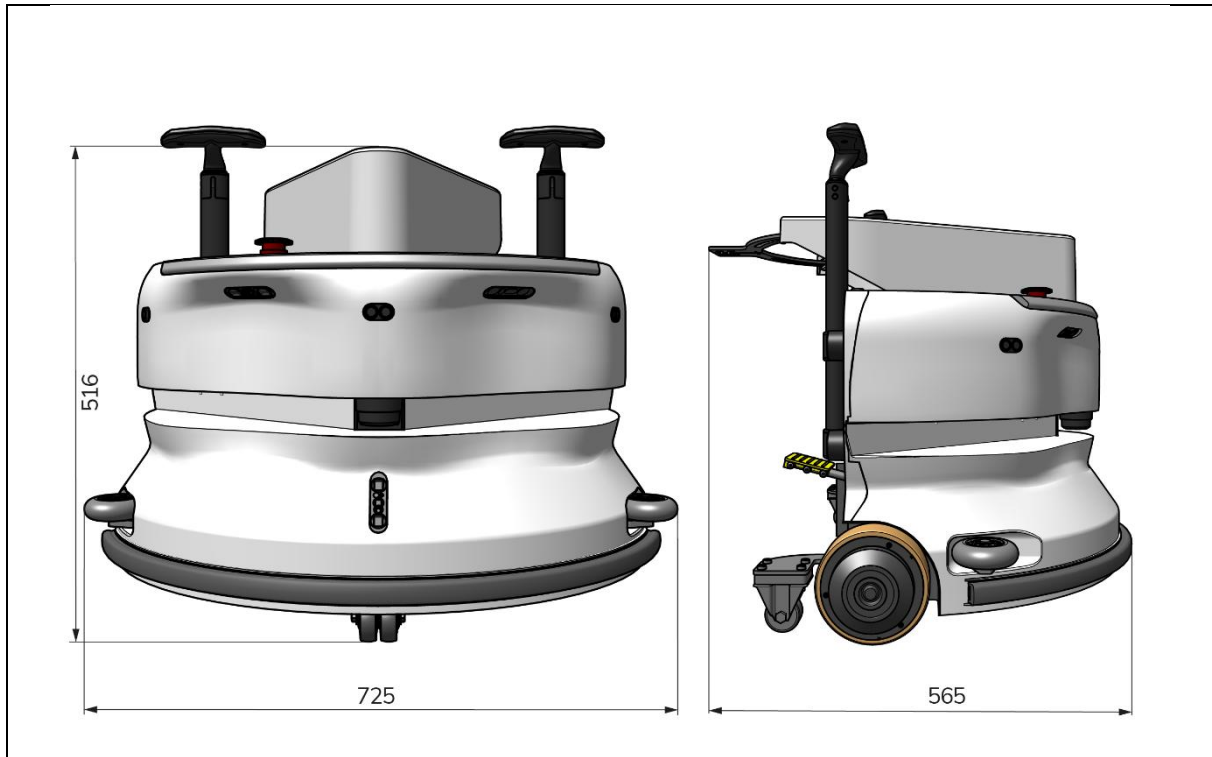

Figure 2

Theoretical performance:	1325 m ² /h
Battery Life:	~ 4 hours (1x i-power 9) ~ 7 hours (1x i-power 14)
Sensors:	2D LiDAR (x1) 3D TOF sensor (x3) Ultrasonic sensor (x3) Bumper strip (x1) Drive motor torque protection
Sensor range:	Up to 50 m @ 90% reflectivity Up to 15 m @ 15% reflectivity
Operational speed:	0.8 m/s
Weight:	22 kg
Dimensions (L x W x H):	725 x 565 x 516 mm
Features:	Obstacle avoidance (auto fill) Fleet management system Wifi connectivity Sim card

1.6 Warranty

The i-walk should be used as intended and described in this manual. Using the i-walk outdoors will void the warranty on the product.



1.7 Identification

Each i-walk has a unique serial number (Figure 3, pos. 1).

Your i-team partner needs this number when you order parts.

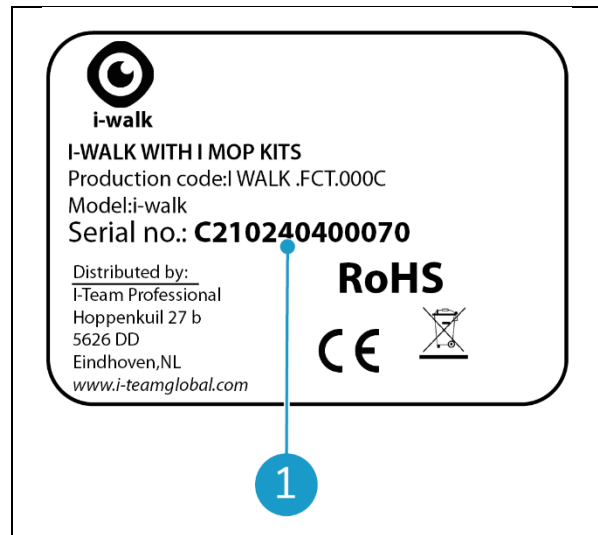

Figure 3

The serial number can be found on the inside of the battery compartment lid (Figure 4, pos. 1).

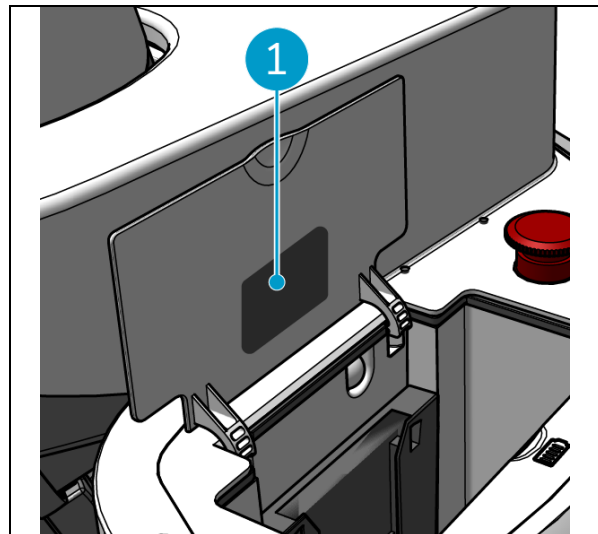

Figure 4



2 Description

The i-walk consists of the following parts:

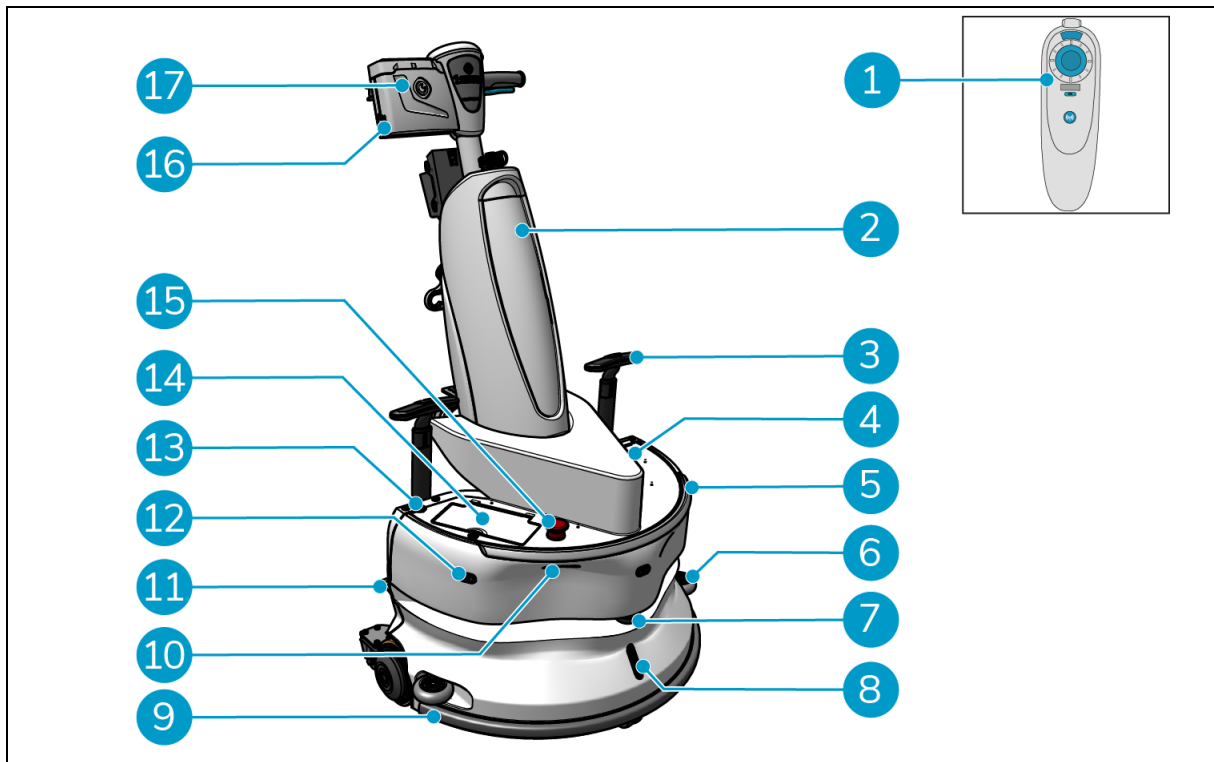

Figure 5

Legend

- | | |
|----------------------------------|---|
| 1. Remote control | 10. Cliff detector sensor (x2) |
| 2. i-mop XL (not included) | 11. Unlock pedal |
| 3. Trolley handle (x2) | 12. Ultrasonic distance sensor (x3) |
| 4. SIM-card slot | 13. Power button |
| 5. Light bar | 14. Battery compartment |
| 6. Side guard bumper wheels (x2) | 15. Emergency stop button |
| 7. High quality LiDAR | 16. Handle controller battery compartment |
| 8. TOF sensor | 17. Handle controller |
| 9. Safety bumper with auto stop | |



2.1 Remote control

The remote control consists of:

1. Antenna
2. Joystick
3. Power button
4. Connect button
5. On/Off indicator

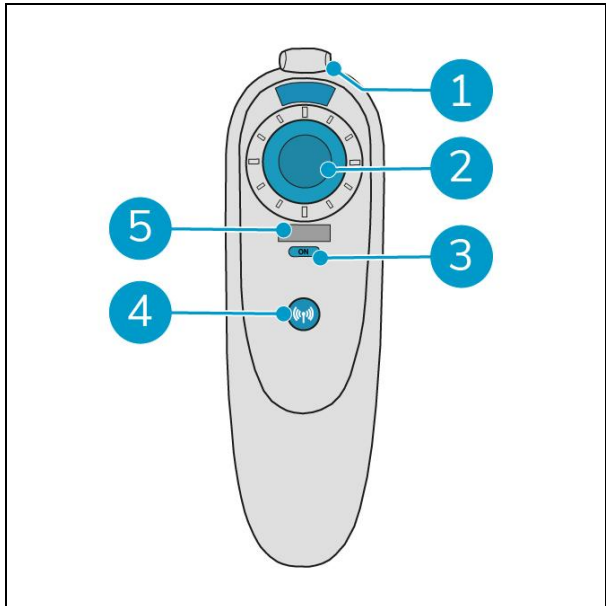

Figure 6

2.2 Handle controller

The handle controller has the following buttons:

1. ON/OFF button
2. LOCK/UNLOCK button
3. AUTO FILL button
4. TEACH REPEAT button
5. START/STOP button
6. CANCEL button

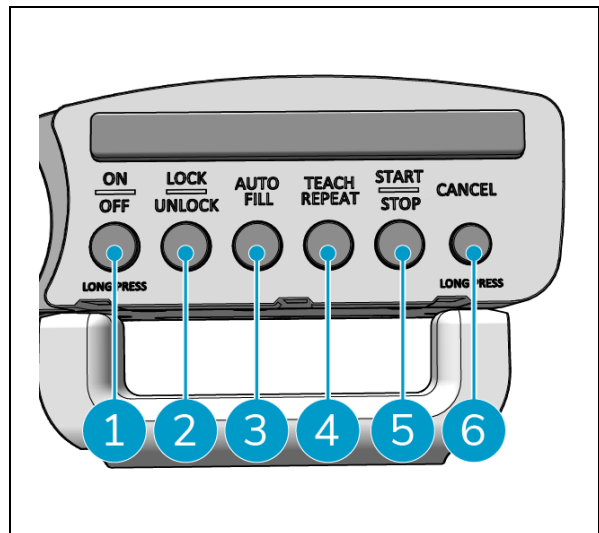

Figure 7



2.3 Main menu of the i-walk app

The main menu of the i-walk app shows information about a site, task reports and a summary of cleaning data for all i-walk devices on that site, see section 6.5.

When opening the i-walk app, you might be required to log in. Use the following details:

- User name: The last 9 digits of the serial number, see section 1.7
- Password: 12345678

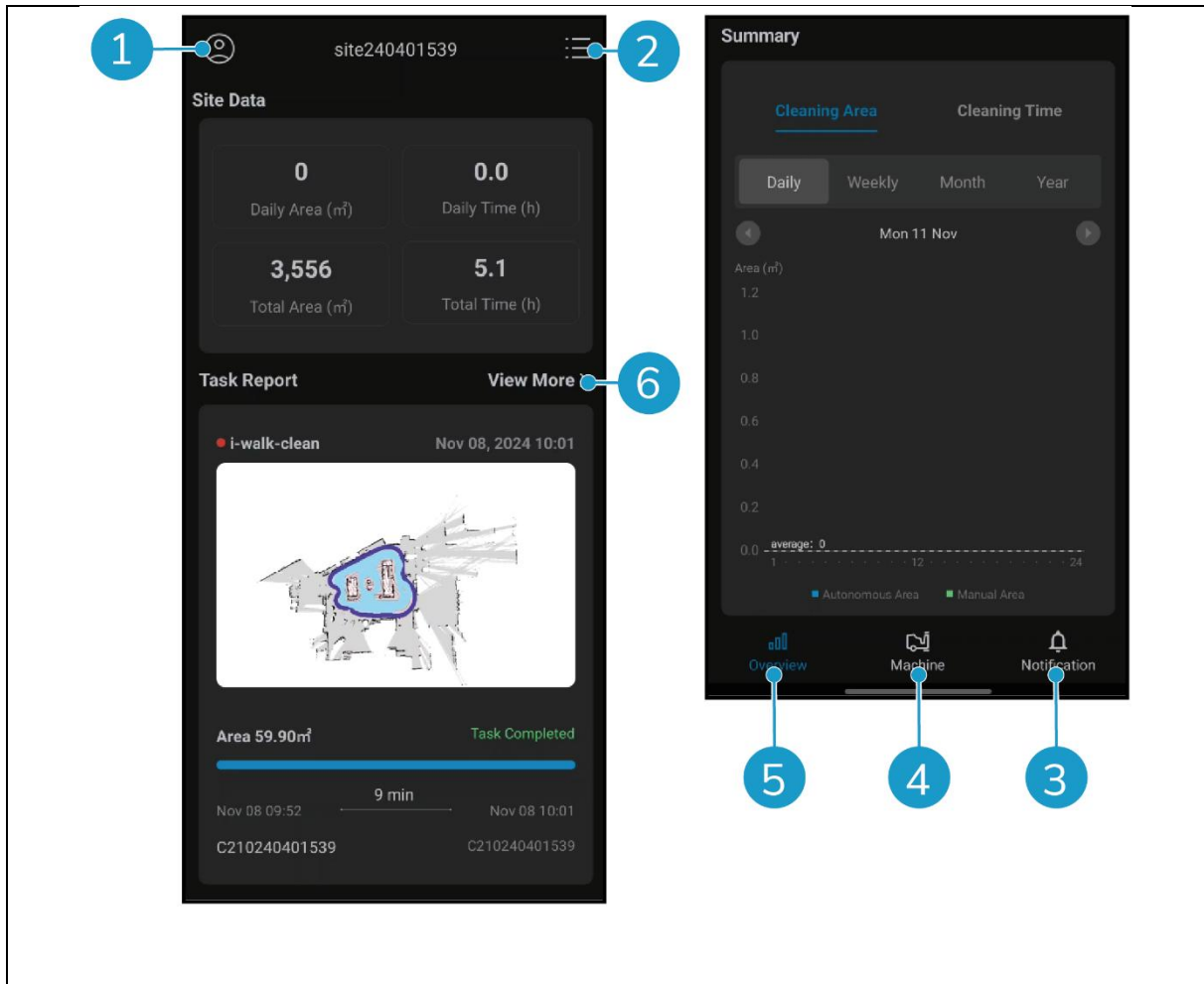

Figure 8



3 Safety

Safety comes first. Therefore, please take your time to read and understand these safety instructions. Improper use can cause harm or void the manufacturer's warranty.

3.1 General safety instructions

3.1.1 Sweep before scrub

Remove objects from the floor that can be propelled by the rotating brush.

3.1.2 Machine orientation

Always keep the main body of the i-walk in an upright position when inserting the battery or sim card.

3.1.3 Batteries

Always use the automatic battery charger provided by the manufacturer.

CAUTION

During normal operation, the 24 V battery and 25.2 V battery cause no safety hazard on their own. Please adhere to the following safety instructions regarding batteries:



- Do not crush, pierce or damage batteries in any way.
- Do not heat or incinerate batteries.
- Do not short-circuit batteries.
- Do not dismantle batteries.
- Keep all batteries dry.
- Only charge between 5 °C~40 °C / 41 °F~104 °F.
- Only use between 5 °C~45 °C / 41 °F~113 °F.

3.1.4 i-mop XL safety

Refer to the manual of your i-mop XL before use and adhere to all safety instructions that apply to the i-mop XL.

3.2 Risks during operation

3.2.1 Radio interference

The i-walk is a Class A product which may cause radio interference. If this is the case, the operator may need to take practical steps against interference, such as planning another path or shutting down equipment.

3.2.2 Transparent materials

Although additional sensors have been installed and measures have been taken, glass walls or other highly transparent materials may affect the i-walk sensor function. Therefore, it is recommended to keep the i-walk away from such materials.



3.2.3 Mark the job site

The i-walk is designed to leave a dry floor without slippery patches, no additional drying is required. When running the i-mop XL with the vacuum function OFF please mark the job site with a wet floor marker.



WARNING

In the event of an accident, press the emergency button on top of the i-walk. This will prevent the i-walk from causing harm.

3.3 Risks after operation

3.3.1 Remove the battery



CAUTION

Before removing the batteries, make sure to turn off the i-walk via the power button on the main unit (see Figure 5, pos. 13) and the ON/OFF button on the handle controller (see Figure 7, pos. 1). Removing the batteries without turning off the i-walk may result in the battery 'sparking' and causing problems with the connectors.

It is best practice to remove the battery after executing any cleaning or maintenance task. Be sure to take the battery out in case of long-term storage.

3.3.2 Careful when storing

Do not store the i-walk on ramps or slopes. Always store the i-walk on a level, hard surface.



4 Transport and storage

4.1 General



CAUTION

Always keep the main body of the i-walk in the upright position.

Before storage or transport, disconnect the main body and the handle controller of the i-walk from the i-mop XL. Remove the batteries after each use.

4.2 Store position

The correct store position is the upright vertical position. Refer to the documentation of your i-mop XL for information on storing your i-mop XL.

4.3 Transport inside/outside



CAUTION

The wheels of the i-walk are not designed to roll over dirty surfaces. Sand can cause the wheels to block. Lift the i-walk while moving it from one building to another.



CAUTION

The i-walk is heavy. Do not try to carry the unit by yourself. You should always use someone's help.

When transporting the i-walk inside:

2. Move the i-walk to its destination using the handles (Figure 9, pos. 1).

When transporting the i-walk outside:

3. Move the i-walk to its destination using the handles (Figure 9, pos. 1).



Figure 9



4.4 Transport in a vehicle

The i-walk is a compact machine and fits in the trunk of your car. Before loading the i-walk into your vehicle, make sure that the batteries are removed.

Do the following:



CAUTION

The i-walk is heavy. Do not try to carry the unit by yourself. You should always use someone's help.

1. Lift the i-walk into your vehicle by lifting it at the bottom.
2. Prevent the i-walk from moving around during transport by using a tension belt or another appropriate restraint.



5 Assembly and installation

The requires some assembly before use. You will have to insert the batteries into the main unit and the handle controller. You will also need to connect the main unit and the handle controller of the i-walk to and i-mop XL.

5.1 Unboxing

The i-walk is packed in a single box. The battery for the main unit and charger are optional. They can be ordered separately as they can also be used for other i-team products. When ordered with the i-walk, they are packed in the same box in a separate compartment.

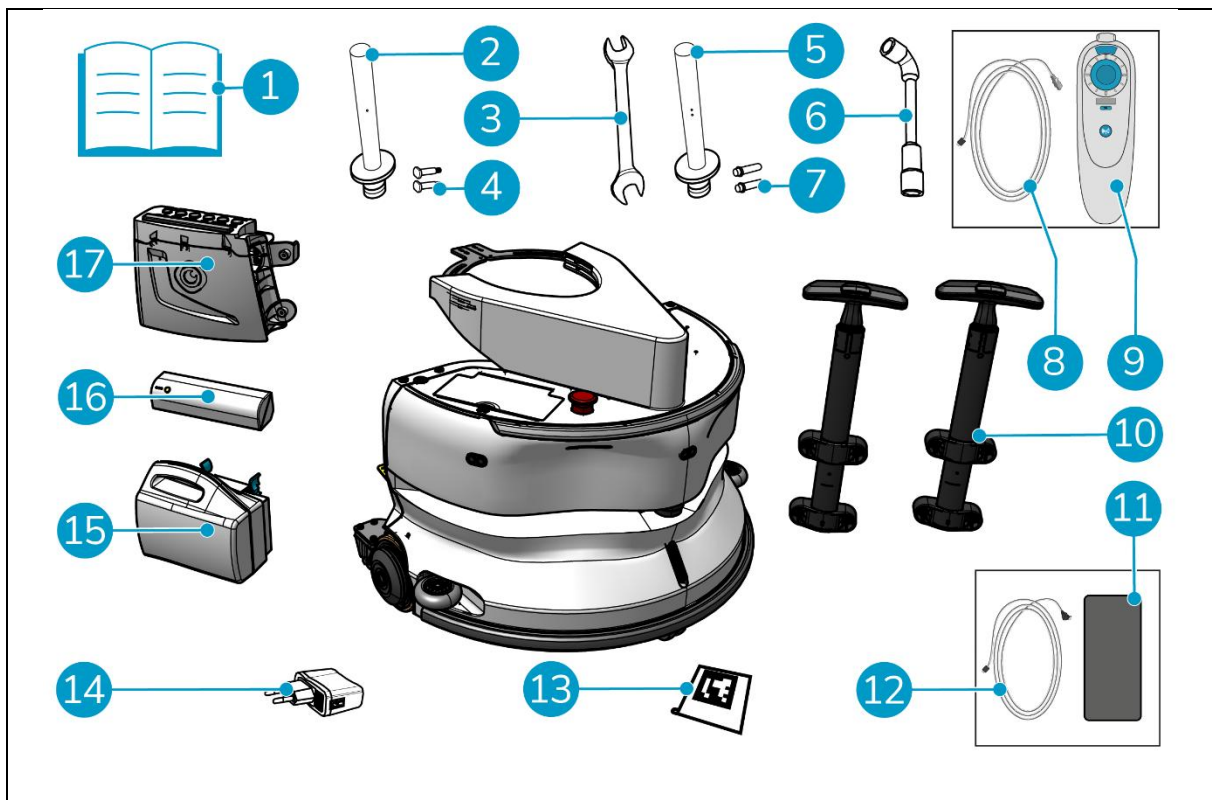

Figure 10

Legend

- | | |
|--------------------------------|---|
| 1. In-the-box product manual | 10. Trolley handle (x2) |
| 2. Connection bar type I | 11. Android phone with i-walk app installed |
| 3. Spanner | 12. Charger + cable for android phone |
| 4. Dedicate axle type I (x2) | 13. QR code block (x10) |
| 5. Connection bar type II | 14. USB power adapter with 4 plug connections |
| 6. Socket spanner | 15. i-power 9 or i-power 14 (optional)* |
| 7. Dedicated axle type II (x2) | 16. i-power 5 (optional)* |
| 8. USB-C to USB-A cable | 17. Handle controller |
| 9. Remote control | |

* The i-power 5 and i-power 9 or i-power 14 battery are not included by default, but can be optionally ordered.



5.2 Assembly

5.2.1 Charging the battery

Charge the battery according to the instructions in the battery charger manual. Make sure the battery is charged regularly.

5.2.2 Inserting the batteries



CAUTION

Only use i-power® batteries specifically designed for use in the i-walk.

1. Open the battery compartment lid on the main unit (Figure 11, pos. 1).
2. Push the battery (Figure 11, pos. 2) in the battery slot. A click indicates that the battery is locked.
3. Close the battery compartment lid.

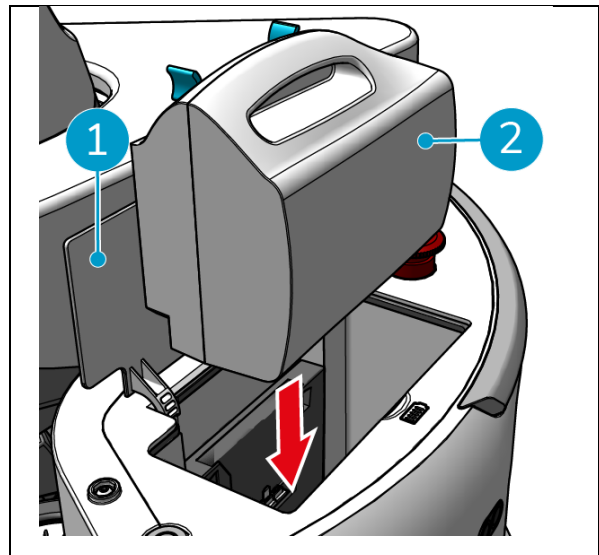

Figure 11

4. Press the power button (Figure 12, pos. 2) on the battery for the handle controller (Figure 12, pos. 1) to turn it on.
5. Slide the battery for the handle controller into the handle controller. A click indicates that the battery is locked.

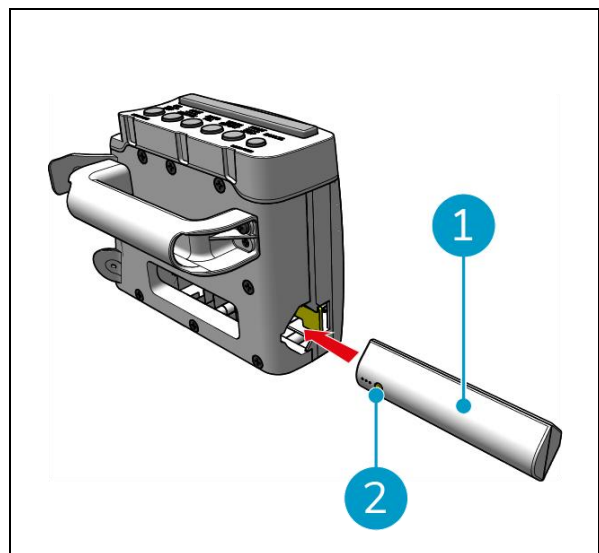

Figure 12



5.2.3 Charging the remote control battery

To charge the remote control battery, you must use the supplied USB-C to USB-A cable.

To charge the remote control battery, do the following:

1. Connect the USB-C connector from the USB-C to USB-A cable to the USB-C port (Figure 13, pos. 1) of the remote control.
2. Connect the USB-A connector to the USB-A port of a power adapter or a laptop.

The battery will be charged.

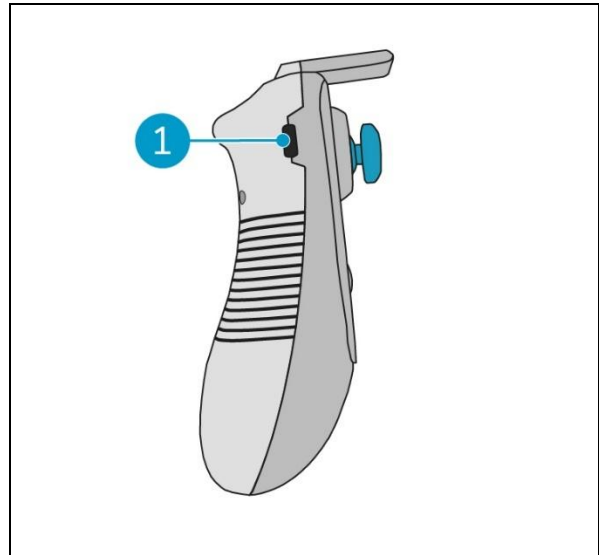

Figure 13

5.2.4 Preparing the i-mop XL

To connect the main unit of the i-walk to the i-mop XL, you must first connect the right steel bar to the i-mop XL. Refer to the model of your i-mop XL to determine which steel bar to use. The installation process is the same for both steel bars.

1. Use the provided wrench (Figure 10, pos. 3 & 6) to remove the front wheels (Figure 14, pos. 2) from the i-mop XL.
2. Remove the existing wheel axles (Figure 14, pos. 1).

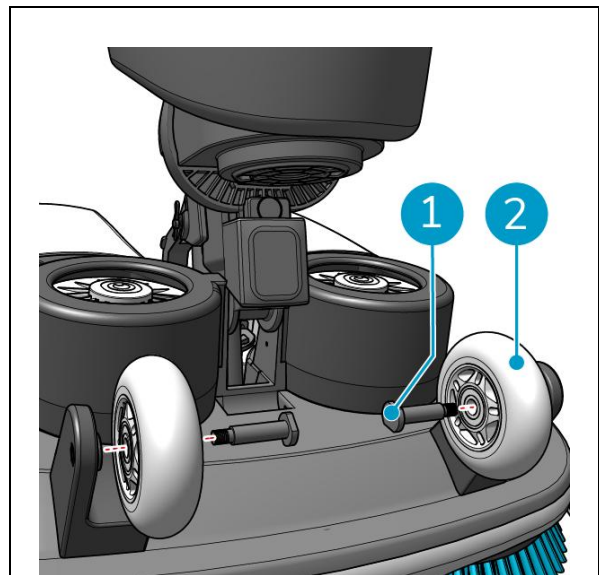

Figure 14



The i-walk comes with 2 sets of connection bars and dedicated axles. The type to be used depends on the transport wheels of your i-mop XL:

- L-shape transport wheel:
Connection bar with 1 hole (Type I) and corresponding axles (Figure 10, pos. 2 & 4)
- U-shape transport wheels:
Connection bar with 2 holes (Type II) and corresponding axles (Figure 10, pos. 5 & 7)

3. Reinstall the wheels with the dedicated axles (Figure 15, pos. 1).

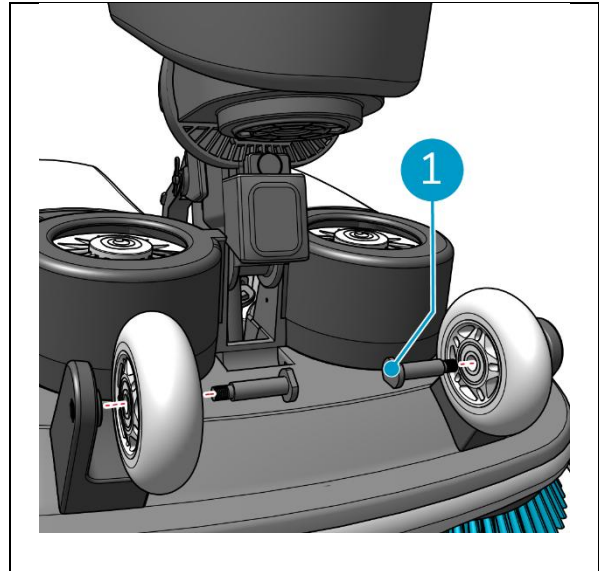

Figure 15

4. Place the steel bar (Figure 16, pos. 1) between the two wheels of the i-mop XL and tighten the small ring (Figure 16, pos. 3).
5. Tighten the large ring (Figure 16, pos. 2) to secure the connection.

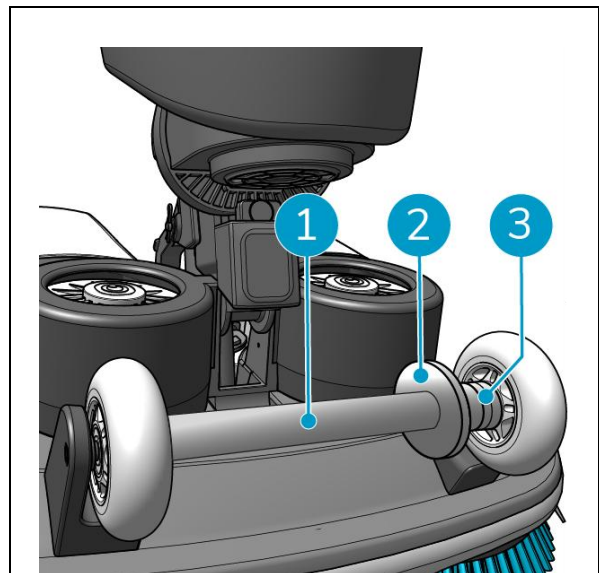

Figure 16



5.2.5 Installing the trolley handles (optional)

1. Install both trolley handles (Figure 17, pos. 1) on the i-walk with a Phillips head screwdriver.

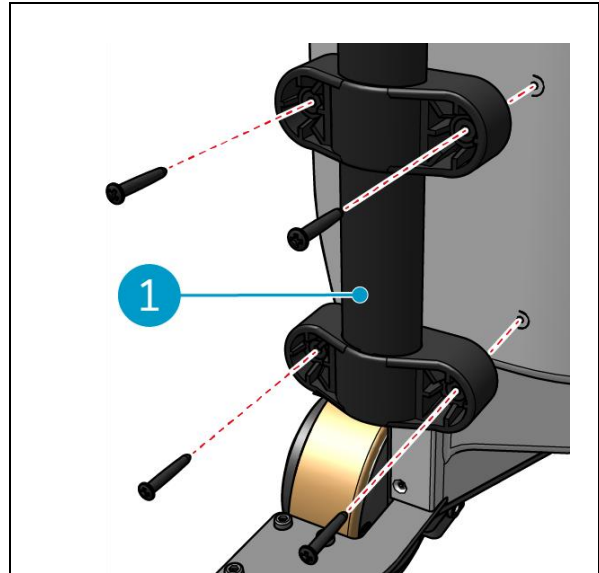

Figure 17

5.2.6 Connecting the i-walk to the i-mop XL

Ensure that the i-mop XL has been set up for use according to the instructions in the i-mop XL user manual.

1. Slide the handle controller (Figure 18, pos. 1) onto the handle of the i-mop XL.

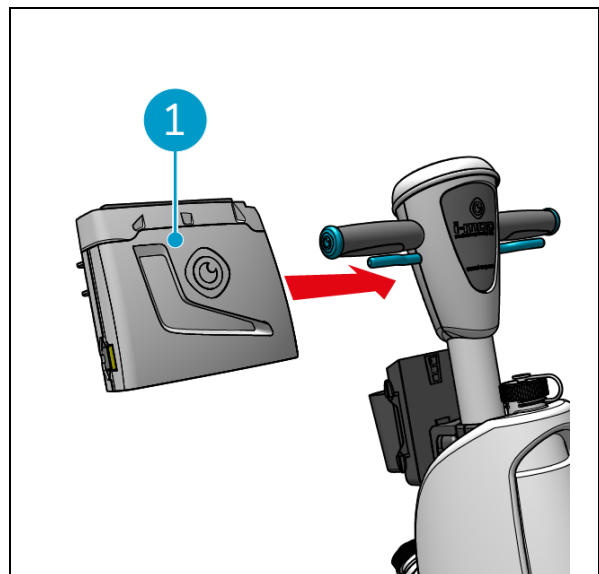

Figure 18

2. Press the Lock button (Figure 19, pos. 1) on the handle controller. The light will be blue to confirm that the wheels of the main unit of the i-walk are locked.

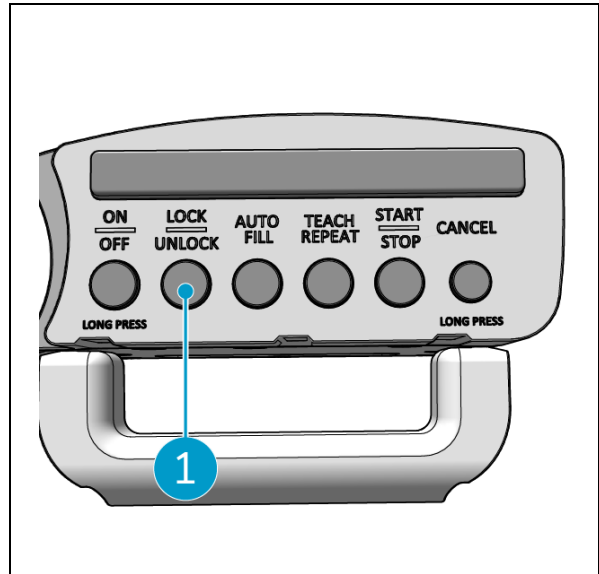

Figure 19

3. Push the i-mop XL into the main unit of the i-walk with some speed. The i-walk will lock onto the steel bar of the i-mop XL. Moving the i-walk too slowly will not trigger the lock mechanism.
4. Close the fix ring (Figure 20, pos. 1) around the i-mop XL.

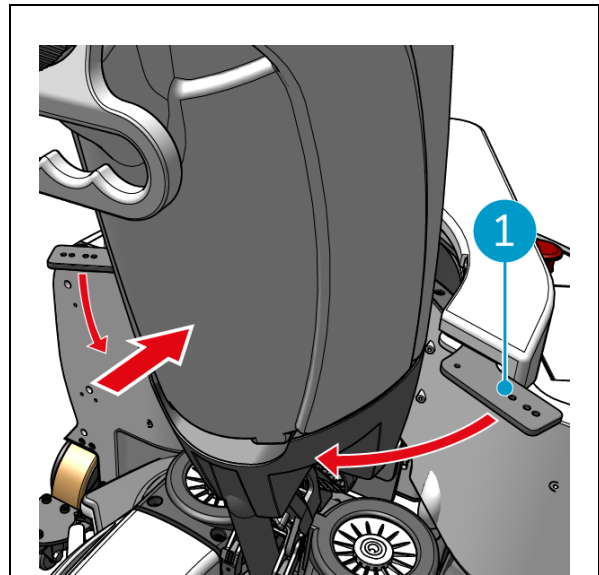

Figure 20

5. Lock the fix ring by turning the butterfly clasp (Figure 21, pos. 1) clockwise.
The i-walk is ready for use.

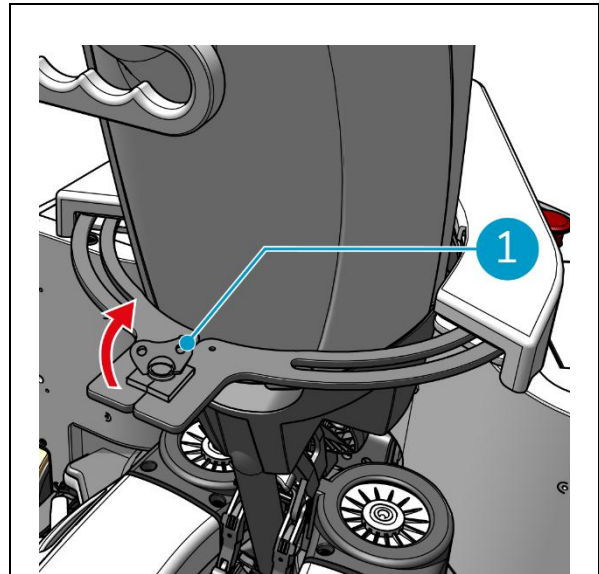

Figure 21

6 Operation

6.1 Before you start



ATTENTION

Always check the following items before starting to make sure your i-walk is ready for use.

Before operating the i-walk, make sure that:

- The batteries of the i-walk are installed, see section 5.2.2, and fully charged, see the manual of the battery charger;
- The battery of the remote control is fully charged, see section 5.2.3;
- The i-mop XL is correctly set up, see the manual of your i-mop XL.

6.2 Setting up the i-walk

6.2.1 Powering-on and unlocking the i-walk

1. Press the power button on the main unit (Figure 5, pos. 13), the i-walk will now power on.
2. Press the ON/OFF button on the handle controller for a few seconds (Figure 7, pos. 1), the handle controller will now power on. A solid blue light indicates a successful Bluetooth connection.
3. Press the LOCK/UNLOCK button on the handle controller, (Figure 7, pos. 2), the i-walk will now be unlocked.



6.2.2 Placing the QR code block

1. Place the QR code block on the wall between 25-40 cm above the floor (Figure 22, pos. 1).

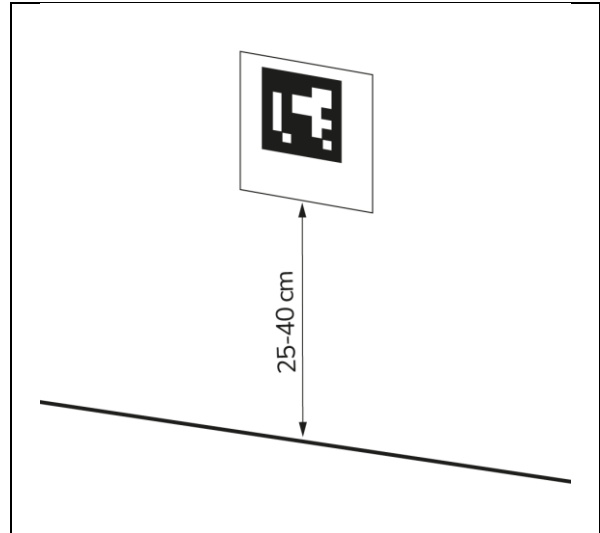

Figure 22

6.2.3 Connecting the i-walk to the network (optional)

The i-walk can be connected to the network via a SIM card. When a SIM card is used to connect to the network, it will connect automatically after inserting the SIM card. Make sure the i-walk is turned off when inserting the SIM card.

Connecting to the network via a SIM card:

1. Remove the cover plate (Figure 23, pos. 1).
2. Open the rubber cap on the SIM card slot (Figure 23, pos. 2).
3. Insert the SIM card into the SIM card slot.
4. Close the rubber cap.
5. Replace the cover plate.

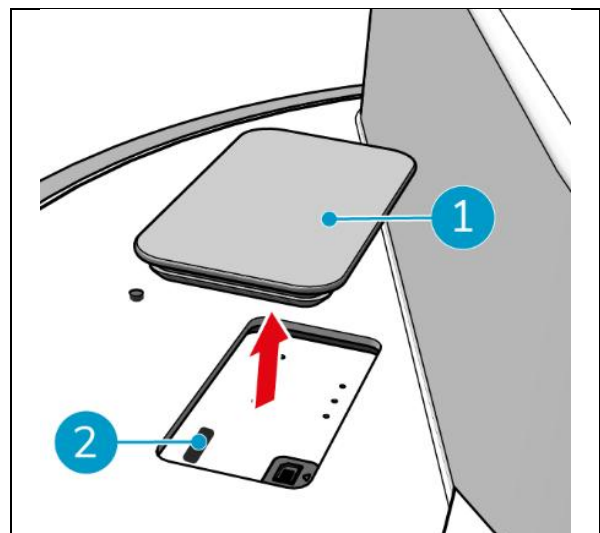

Figure 23

6.2.4 Turning on and connecting the remote control.

The remote control is linked to this specific i-walk.

1. Press the power button to turn on the remote control
2. Press the connect button to connect the remote control to the i-walk.

The i-walk ring will start “breathing” blue light, indicating that it is connected to the remote control.



6.3 Auto Fill mode

The Auto Fill mode allows you to set a boundary for an area you want to clean. The i-walk will clean the entire area within the boundary and will never leave the created area. Note that the stand-alone Auto Fill task will only be executed once and then forgotten by the i-walk.

1. Press the Auto Fill button (Figure 24, pos. 1). The Auto Fill button will be white.
2. Guide the i-walk around the boundary of the area you want to clean. When you arrive at the starting point, the Start/Stop button (Figure 24, pos. 2) will flash blue.
3. Press the Start button to begin the automatic cleaning. After cleaning, the i-walk returns to the starting point and automatically stops.

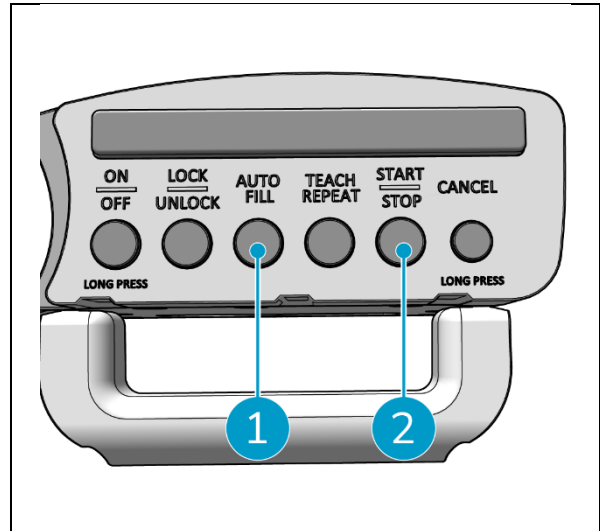

Figure 24

6.3.1 Auto Fill with QR code

Ensure the QR code block has been placed on the wall, see 6.2.2.

1. Position the i-walk about 30 cm in front of the QR code (Figure 25, pos. 1). The Auto Fill button and Teach Repeat button will flash blue when the QR code is recognized.

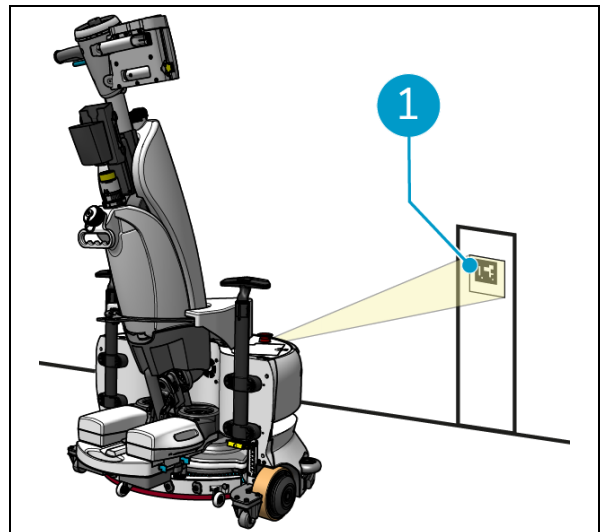

Figure 25

2. Press the Auto Fill button (Figure 26, pos. 1). The Auto Fill button will be white.
3. Guide the i-walk around the boundary of the area you want to clean. When you arrive at the starting point, the Start/Stop button will flash blue.
4. Press the Start button (Figure 26, pos. 2) to begin the automatic cleaning. After cleaning, the i-walk returns to the starting point and automatically stops.
5. Press the Stop button (Figure 26, pos. 2) at any time during the cleaning to stop the i-walk, and use the app to edit the cleaning map, see 6.5.4.
6. Press the Start button to resume the cleaning.

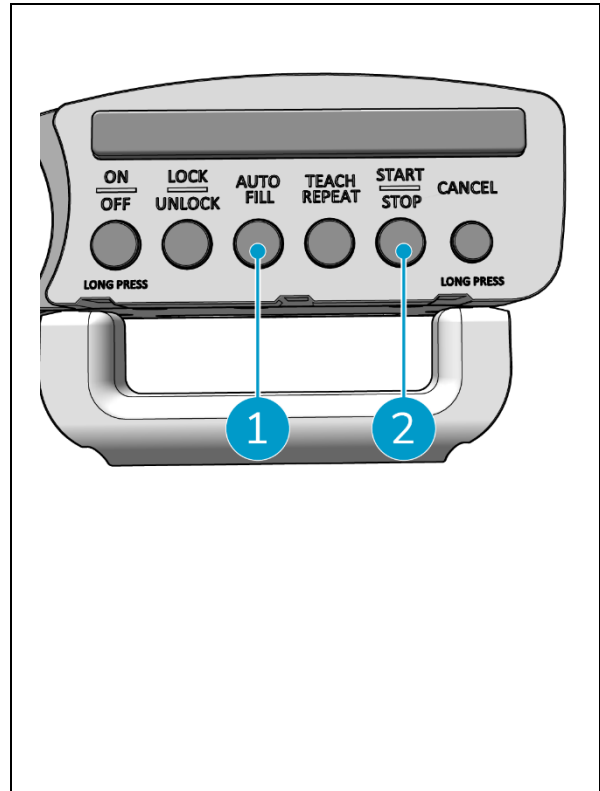

Figure 26

7. If you want to cancel the current task at any time, press and hold the Cancel button until there is a small beep sound and the Cancel button turns red. The i-walk can now be taken do do another task.

6.4 Teach Repeat mode (with QR code)

The Teach Repeat mode allows you to clean an area once and teach the i-walk to clean the area in the future. Ensure the QR code block has been placed on the wall, see 6.2.2.

1. Position the i-walk about 30 cm in front of the QR code (Figure 27, pos. 1). The Teach Repeat button will flash blue when the QR code is recognized.

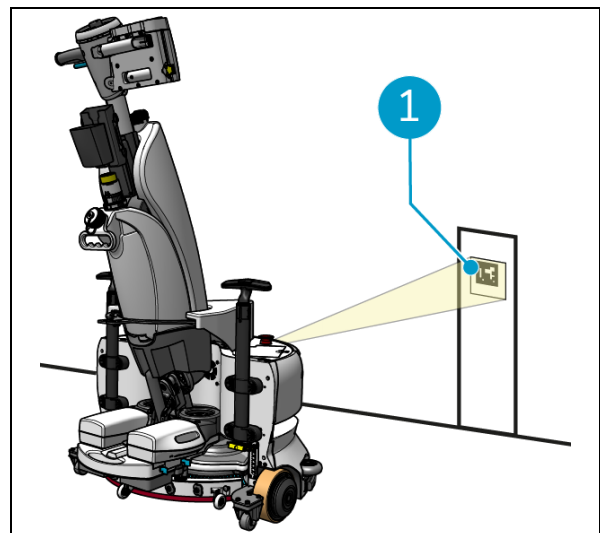

Figure 27

2. Press the Teach Repeat button (Figure 28, pos. 1). The Teach Repeat button will be white.
3. Guide the i-walk around the area you want to clean. When you arrive at the starting point, the Start/Stop button (Figure 28, pos. 2) will flash blue.
4. Press the Start button to save the path.
5. For future cleaning sessions, position the i-walk in front of the QR code again. The Start button will flash blue when the QR code is recognized.
6. Press the Start button to start the cleaning.

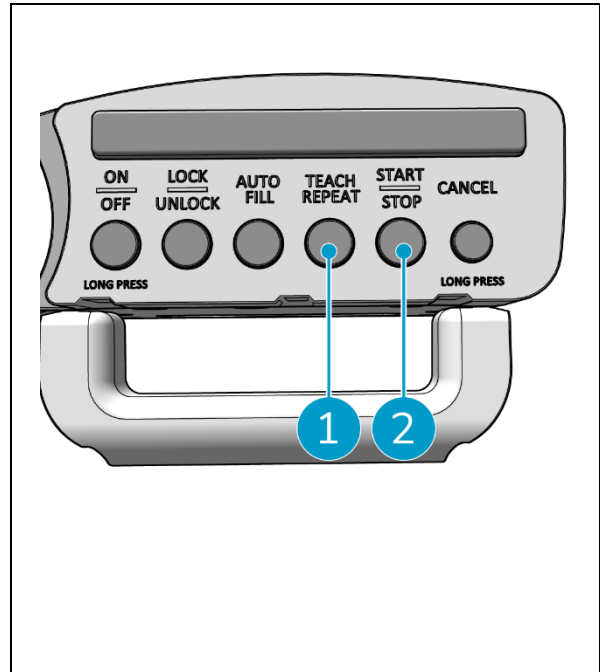

Figure 28

6.5 Using the i-walk app

The i-walk app shows information about your i-walk devices, shows notifications and allows you to edit cleaning maps. The i-walk app is preinstalled on the supplied smartphone.

When opening the i-walk app, you might be required to log in. Use the following details:

- User name: The last 9 digits of the serial number, see section 1.7
- Password: 12345678



6.5.1 Overview

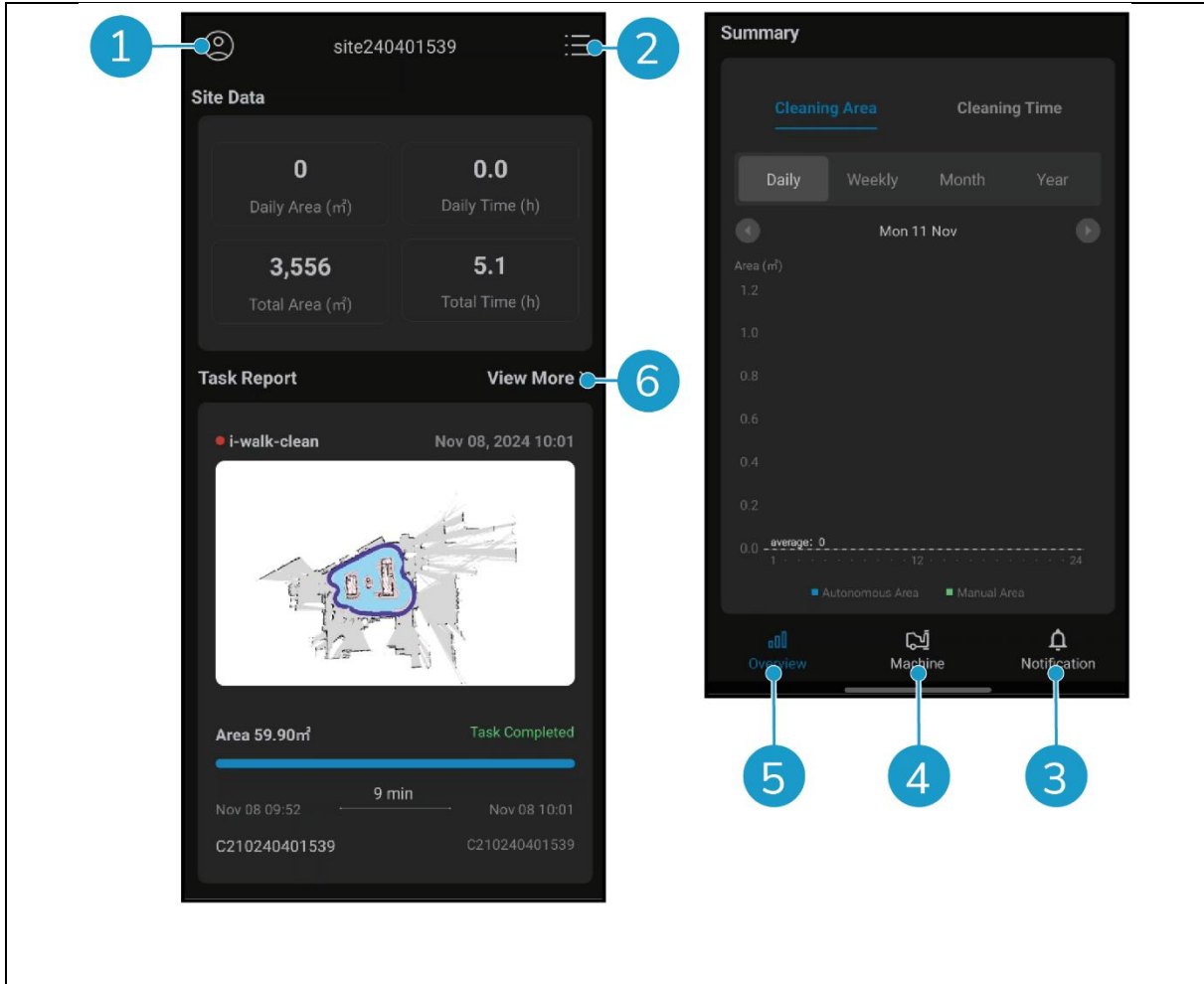

Figure 29

The Overview screen of the i-walk app shows an overview of the currently active site, with data about the site, a task report and information about the cleaning area and time for that site.

- Tap the [\[Profile\]](#) button (Figure 29, pos. 1) to view Site menu.
- Tap [\[View More\]](#) (Figure 29, pos. 6) to open the Task Report.
- Tap the buttons at the bottom (Figure 29, pos. 3 & 4) to switch to the Machine or Notification menu.



6.5.2 Site info

The Site Info menu shows a list of available sites.

- Tap any available site (Figure 30, pos. 1) to go the Overview for that site.

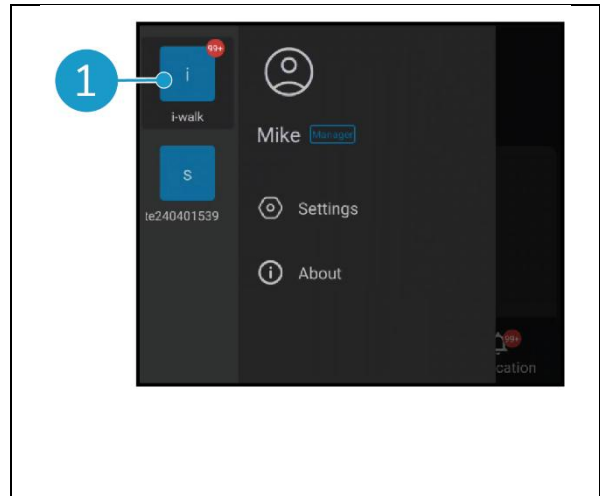

Figure 30

6.5.3 Machine overview

The Machine overview shows a list of machines that are active on your current site.

- Tap any machine (Figure 31, pos. 1) to open the menu for that machine.

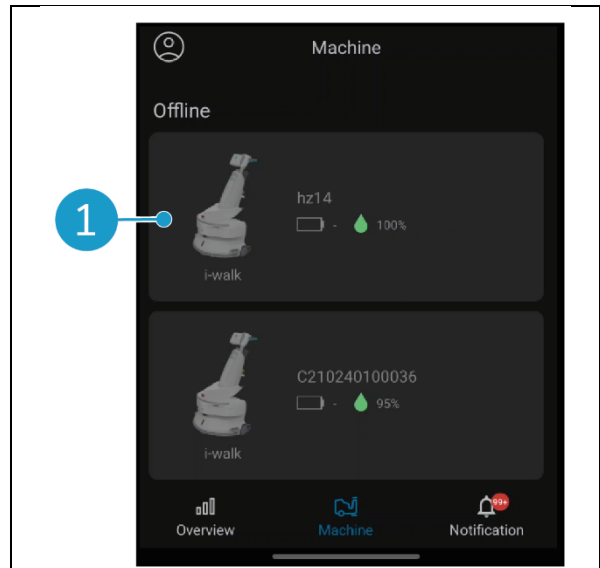

Figure 31



6.5.4 Machine menu

The Machine menu shows information about a specific machine and allows you to edit the cleaning map of that machine.

- Tap the [Nut] icon (Figure 32, pos. 1) to edit the cleaning map. You can draw on the map to indicate areas to avoid.
- Tap the [Report] button (Figure 32, pos. 2) to open the Machine Report.
- Tap the [Task Report] button (Figure 32, pos. 3) to open the Task Report.
- Tap the [Machine Info] button (Figure 32, pos. 4) to view information about the machine.

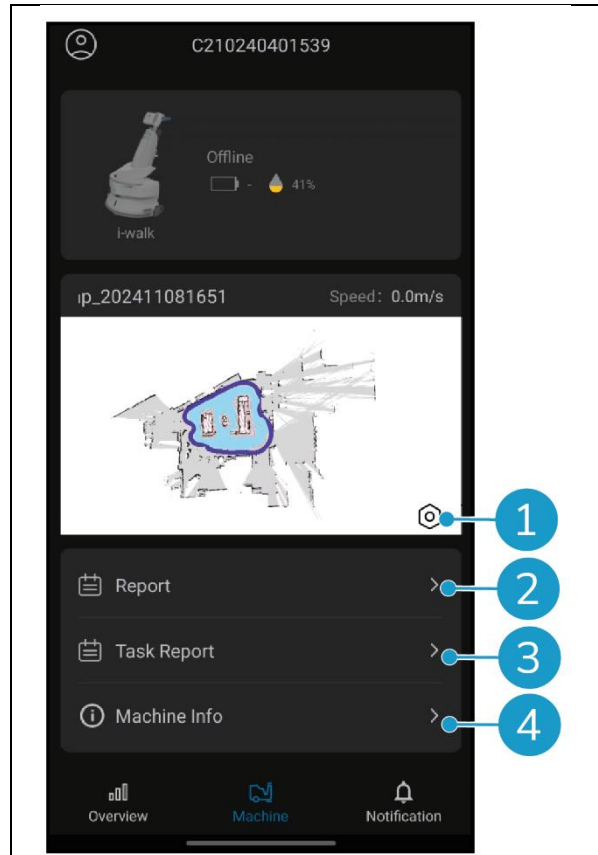

Figure 32



6.5.4.1 Machine report

The Machine Report shows the cleaning data, cleaning area and cleaning time for the machine.

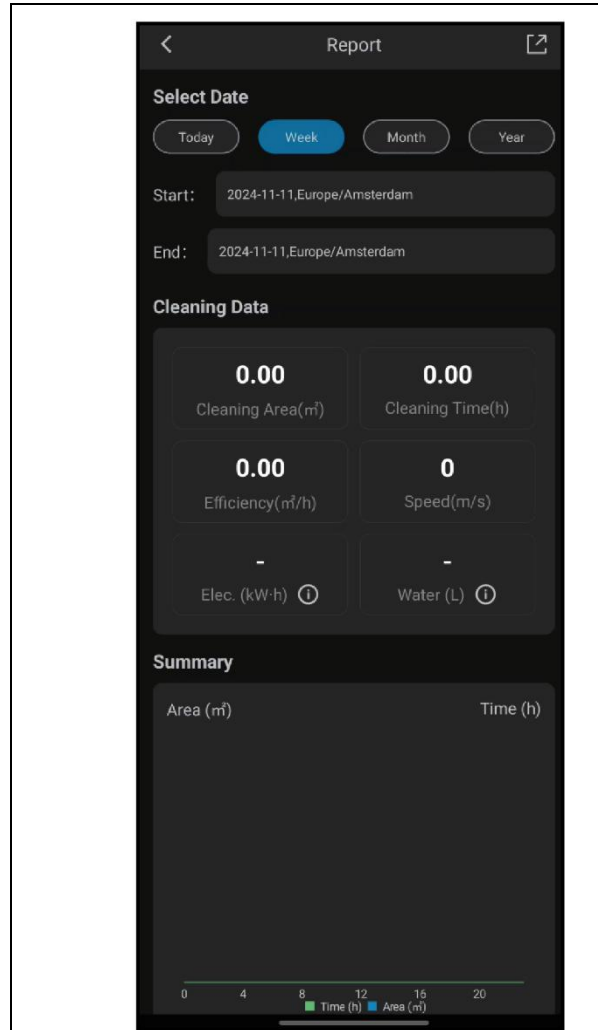

Figure 33

6.5.4.2 Task report

The Task Report shows information about a cleaning task that is in progress or that has been completed.

- Tap the button in the top right (Figure 34, pos. 1) to mark all current reports as read and remove them from the view.
- Tap a report in the list (Figure 34, pos. 2) to open the Task View.

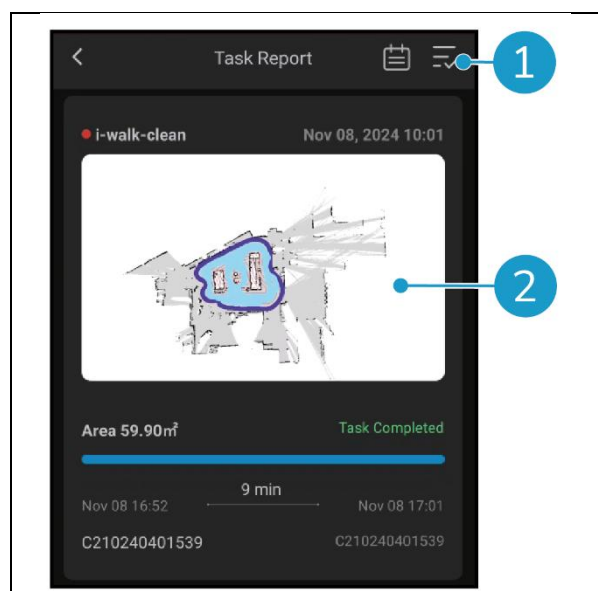

Figure 34

6.5.4.3 Task view

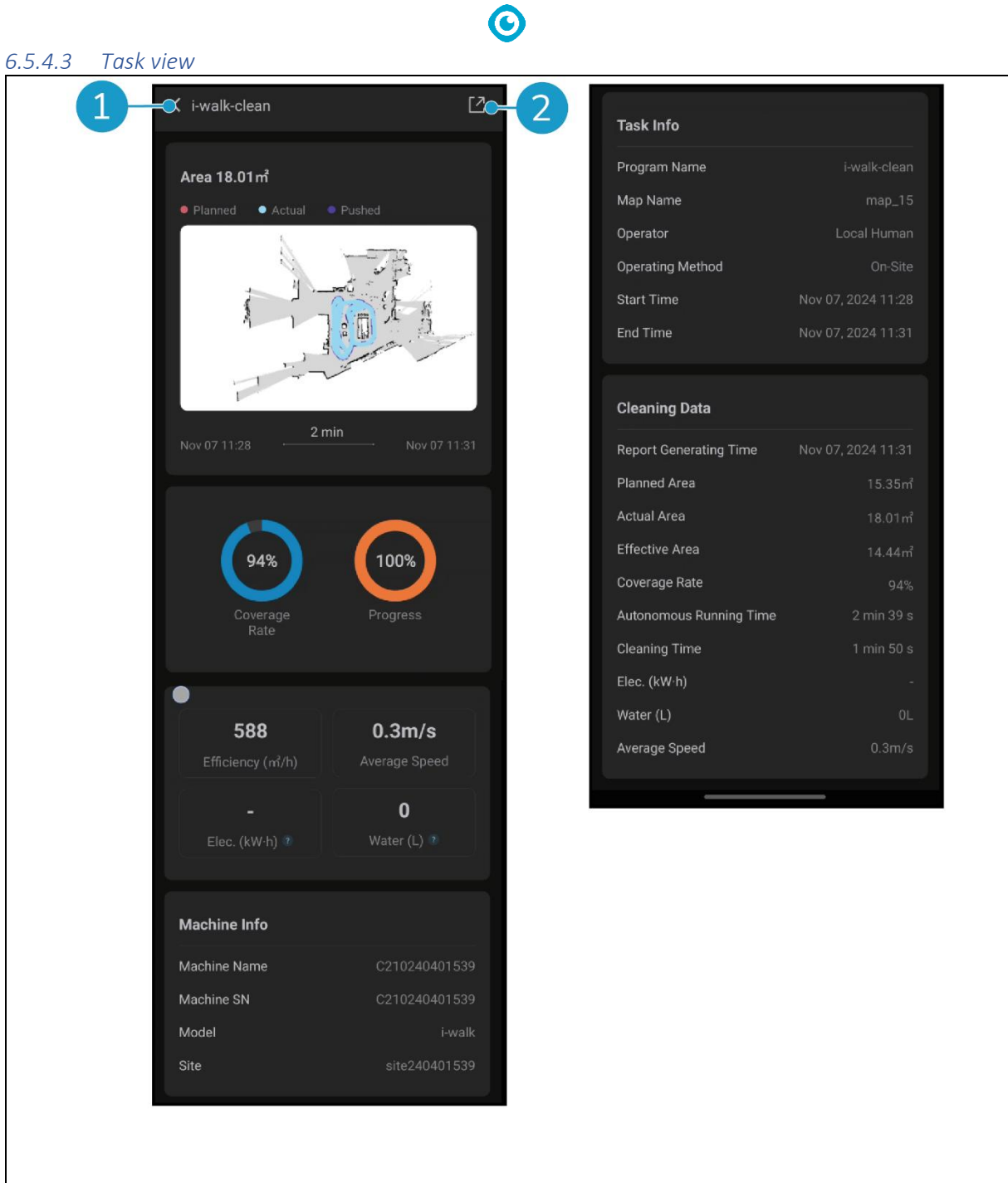

Figure 35

The Task View shows all the information about a cleaning task, including the progress, information about the machine, information about the task and cleaning data.

- Tap the [\[Share\]](#) button (Figure 35, pos. 2) to share or export the cleaning task information.



6.5.4.4 Machine info

The Machine Info menu shows information about a machine, including the name and hardware and software versions.

- Tap the [Self-check] button (Figure 36, pos. 1) to run a diagnostic check on the machine.
- Tap [Remove machine] (Figure 36, pos. 2) to remove the machine from your i-walk app.

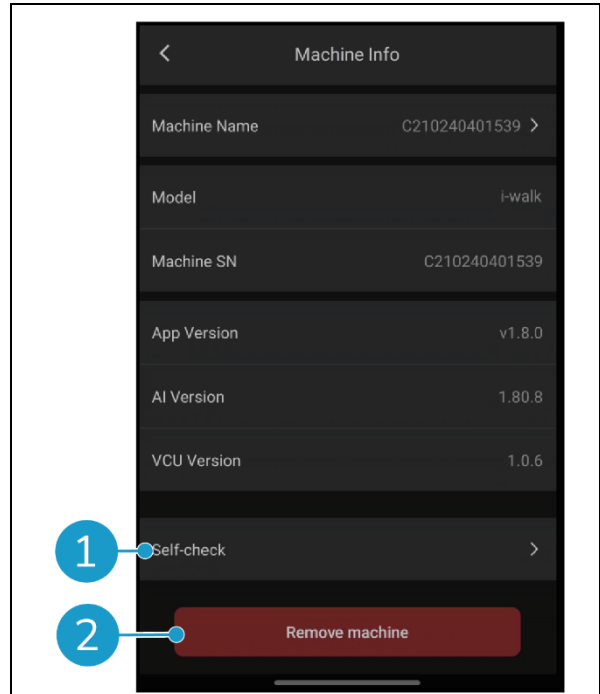

Figure 36

6.5.5 Notification menu

The Notification menu shows a list of notifications from all the machine on a site.

- Tap the button in the top right (Figure 37, pos. 1) to mark all current reports as read and remove them from the view.
- Tap a specific notification (Figure 37, pos. 2) to view it in more detail.

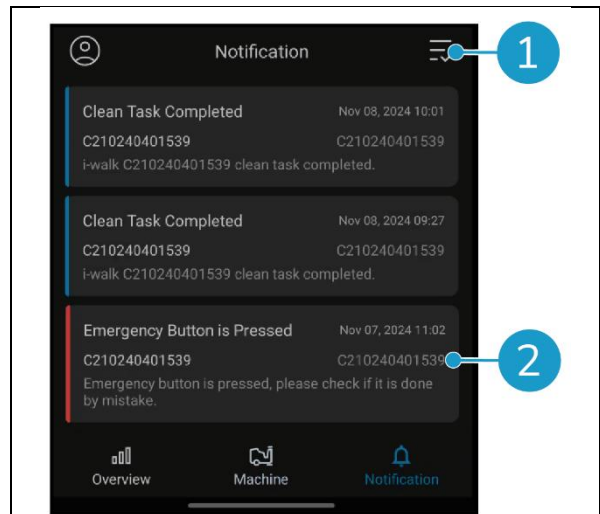

Figure 37



6.5.6 Notification view

Every notification shows information about the machine that is affected and some suggestions in case any follow-up is necessary.

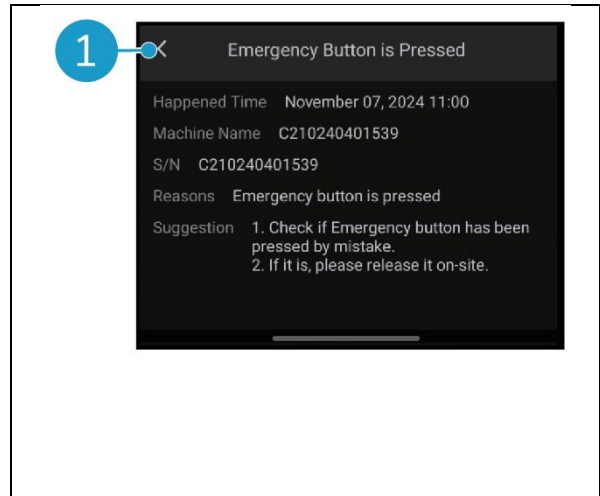

Figure 38

6.6 Deleting a cleaning path

The Auto Fill or Teach Repeat task that has been linked to a QR code can also be deleted.

1. Position the i-walk in front of the QR code. The Start/Stop button (Figure 39, pos. 1) will flash blue when the QR code is recognized.
2. Press and hold the Cancel button (Figure 39, pos. 2) for a few seconds. A beep will confirm the deletion of a cleaning path.

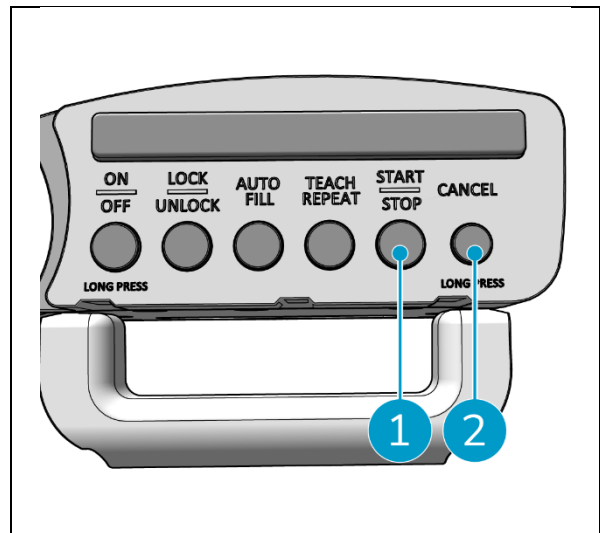

Figure 39

6.7 Emptying and filling water tanks

When the clean water tank of the i-mop XL is empty, the i-walk will automatically stop and the light bar on the front will flash white.

1. Unlock the fix ring of the i-walk (Figure 40, pos. 1).
2. Empty the wastewater tank of the i-mop XL according to the instructions in the manual of your i-mop XL.
3. Refill the clean water tank of the i-mop XL according to the instructions in the manual of your i-mop XL.

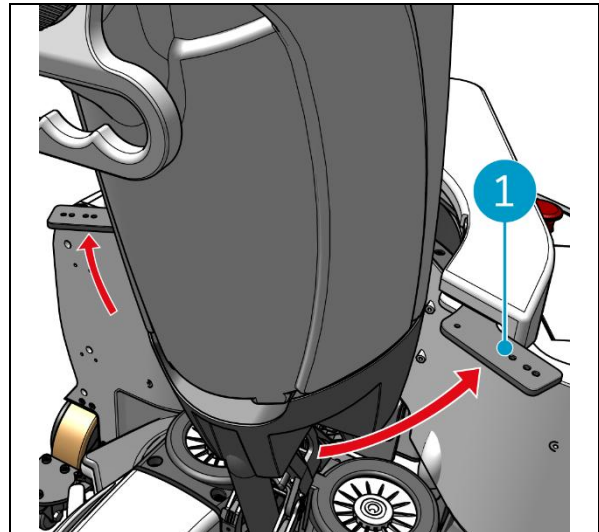

Figure 40

4. Lock the fix ring of the i-walk.
5. Press the Start button (Figure 41, pos. 1) on the handle controller to continue the cleaning for another sessions.

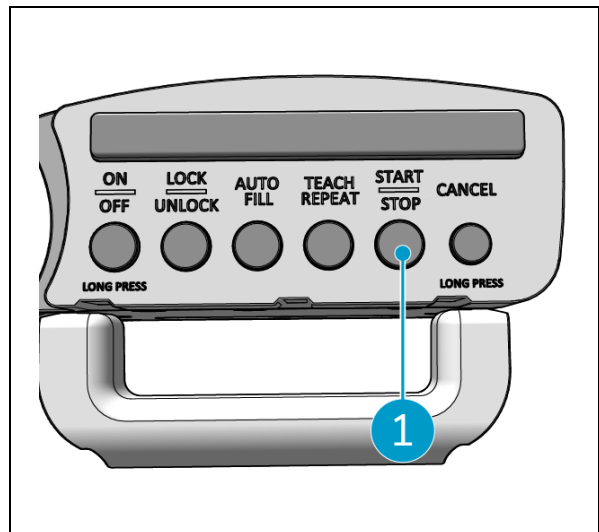

Figure 41

6.8 Pausing the i-walk

1. Press the stop button during operation to pause the i-walk. The Start/Stop button will flash blue.
2. Press the Start button to resume.

6.9 Cancelling a cleaning task

1. Press and hold the cancel button for a few seconds to cancel the current cleaning task. A beep will confirm the cancellation of the cleaning task.



6.10 Emergency stop

1. In case of emergencies, press the emergency stop button on the main unit of the i-walk (Figure 42, pos. 1). The i-walk will stop and the light bar will flash red.

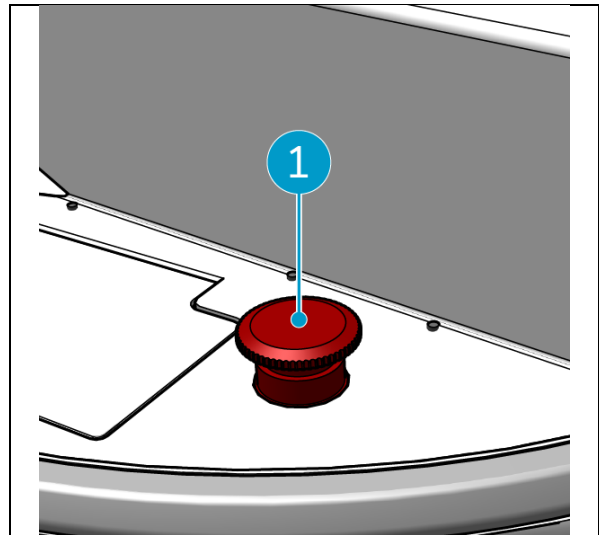

Figure 42

2. Twist the emergency stop button to release it. The light bare will flash white.
3. Press the Start button on the handle controller to activate the i-walk again.

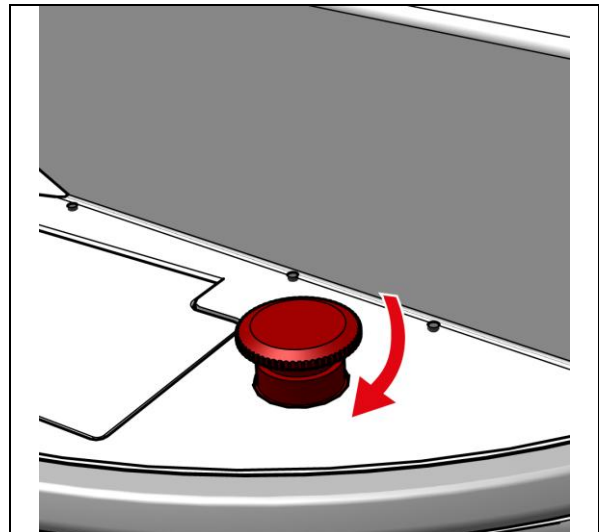

Figure 43



6.11 Shutting down the i-walk

1. Press the power button on the main unit of the i-walk (Figure Figure 5, pos. 13). The light in the power button and the light bar on the front of the i-walk will turn off.
2. Press and hold the ON/OFF button (Figure 44, pos. 1) on the handle controller. The button will flash red once and the lights on the handle controller will turn off.

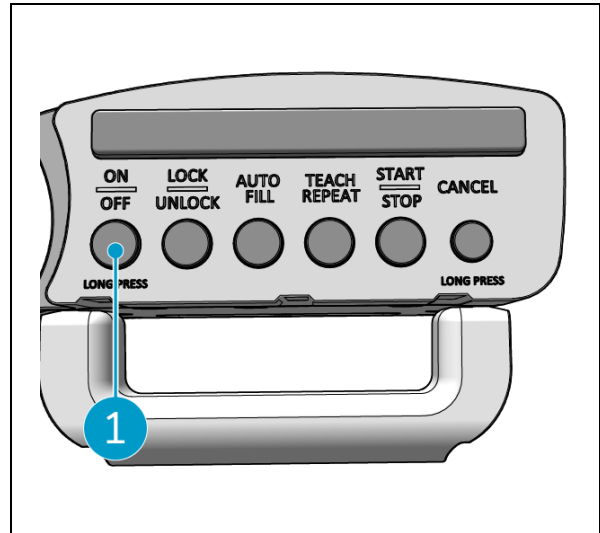

Figure 44

3. Unlock the fix ring on the i-walk (Figure 45, pos. 1).
4. Open the fix ring.

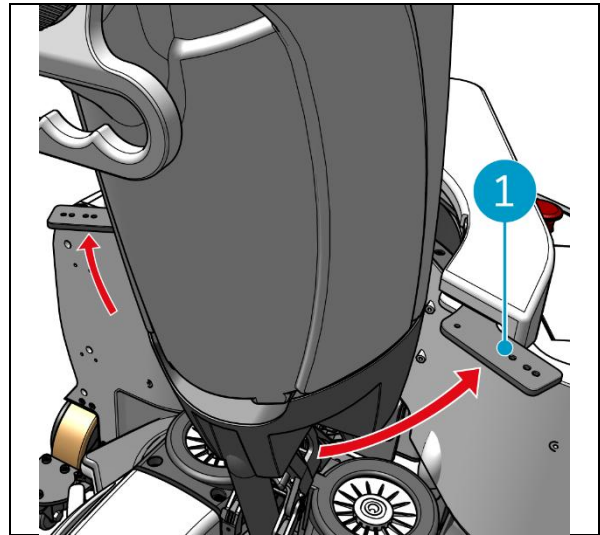

Figure 45

5. Step on the pedal (Figure 46, pos. 1) at the bottom of the main unit to detach it from the i-mop XL.

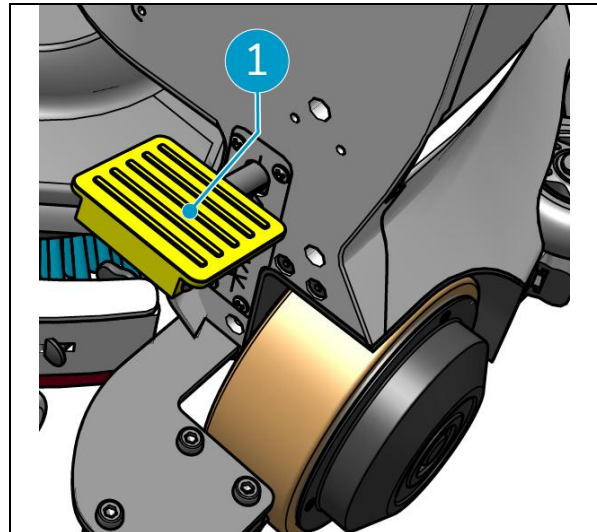

Figure 46

6. Detach the handle controller (Figure 47, pos. 1) from the i-mop XL.

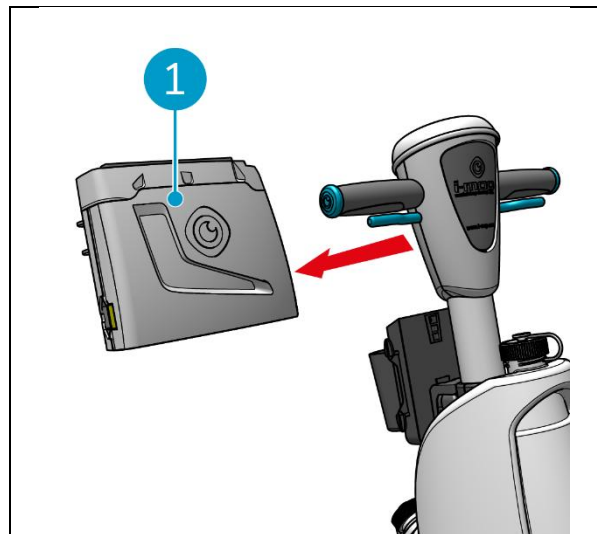

Figure 47

6.12 Linking/resetting the handle controller

To link a new handle controller or reset the connection, follow the steps below:

1. Turn off the main unit of the i-walk with the power button (Figure 5, pos. 13).

2. Press and hold the ON/OFF button (Figure 48, pos. 1) and the CANCEL button (Figure 48, pos. 2) on the handle controller simultaneously. The handle controller will beep 3 times to indicate that the connection has been deleted.
3. Turn on the main unit with the power button (Figure 5, pos. 13).
4. Press the bumper of the main unit (Figure 5, pos. 9) twice quickly. The i-walk will beep several times, after which the light bar will turn white.
5. Press the ON/OFF button (Figure 48, pos. 1) once and the handle will start beeping. The best is to place the handle on top of the i-walk to limit interference.

The handle will stop beeping if the connection has been established.

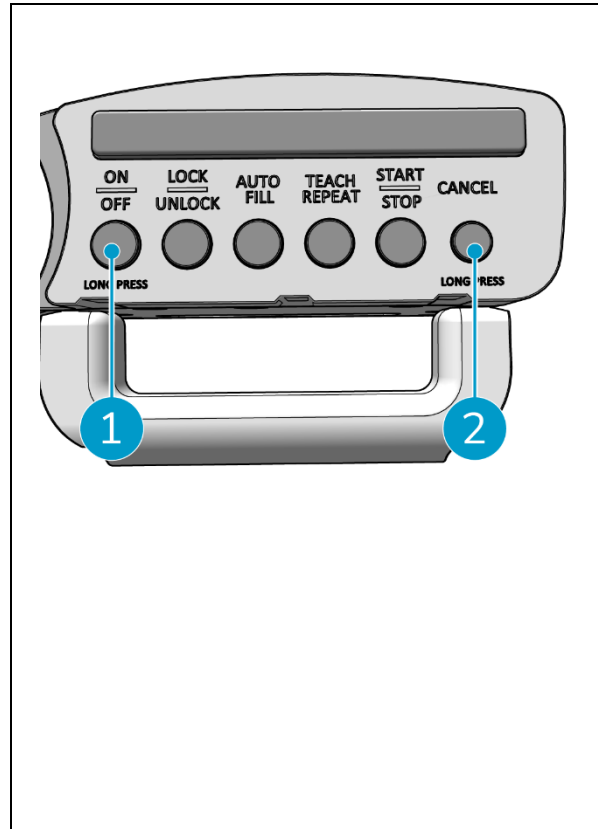

Figure 48

6.13 Cleaning



CAUTION

Remove the battery before executing any cleaning or maintenance task.

6.13.1 Removing the battery

1. Power off the i-walk by pressing the power button (Figure 5, pos. 13).
2. Open the battery compartment lid (Figure 49, pos. 1).
3. While pressing the blue tabs (Figure 49, pos. 3), pull the battery (Figure 49, pos. 2) out of the compartment.
4. Close the battery compartment lid.

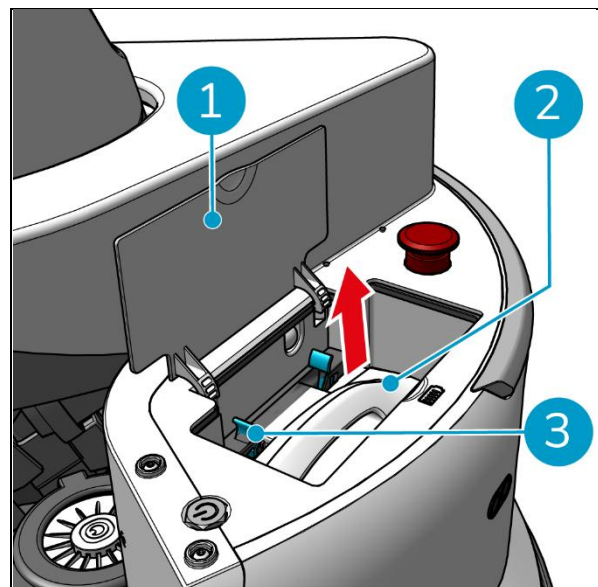

Figure 49

Make sure the battery is charged monthly.



7 Maintenance



CAUTION

Remove the batteries before executing any cleaning or maintenance task.



CAUTION

Always keep the main unit of the i-walk in an upright position when executing any cleaning or maintenance task.

7.1 Daily maintenance

Check that the sensors of the i-walk are clean and the wheels are not damaged.

7.2 Two-weekly maintenance

Component	Action
Ultrasonic distance sensors	Check the ultrasonic distance sensors for dirt.
Cliff detector sensors	Check the cliff detector sensors for dirt.
LiDAR	Check the LiDAR for dirt.
TOF sensor	Check the TOF sensor for dirt

7.3 Recommended additional cleaning

Clean the exterior of the i-walk weekly with a non-abrasive, non-solvent cleaner or a clean, damp cloth.

7.4 Recommend service time

Service must be done by one of our service partners. The first service is recommended after 10,000 hours, when the driving wheels should be replaced.

8 Troubleshooting

If any issue might arise when using the i-walk, please read this chapter first. It consists of two sections:

- Section 8.1 describing the most common problems when using the i-walk.
- Section 8.2 describing the fault prompts on the display of the i-walk.



8.1 Problems

Problem	Cause	Solution
i-walk offline	i-walk is powered off and/or the app is not connected to the i-walk	1. Check if the sim card is functional in another device.
Unable to power on/off the i-walk	Power level of the i-walk is low or there is an error in the power system	1. (Re)charge or replace the battery. 2. If this doesn't help: contact customer service.
Driving errors	i-walk laser radar and/or structured light camera are dirty	Clean the sensors surfaces with a dust-free cloth. If the problem persists, contact customer service.
	Drive motor triggers 'over temperature' protection	Pause the task and wait for the drive motor temperature to settle down.
	i-walk is skidding	Move the i-walk to a place with less water stains on the ground.

8.2 Fault problems

Prompt	Device symptom	Cause	Solution
Emergency stop button pressed	The indicator light is always red	Emergency stop button pressed	1. Confirm whether the emergency stop button has been accidentally pressed. 2. If there is no safety risk, reset the emergency stop button.
i-mop stopped working	Automatically pause autonomous task	i-mop stopped working	1. Check the i-mop. 2. Resume the autonomous task if there are no problems.
i-mop water tank empty	Automatically pause autonomous task	i-walk works continuously for 15 minutes	1. Fill the water tank and drain the recovery tank for i-mop. 2. Resume the autonomous task.



Stay timeout	Automatically pause autonomous task	i-walk stays in one place for too long	<ol style="list-style-type: none">1. Resume the autonomous task.2. If issue persists, contact customer service.
LiDAR error	Automatically pause autonomous task	LiDAR no data	<ol style="list-style-type: none">1. Reboot the machine.2. Restart the autonomous task.3. If issue persists, contact customer service.
Left depth camera error	Automatically pause autonomous task	Left depth camera no data	<ol style="list-style-type: none">1. Reboot the machine.2. Restart the autonomous task.3. If issue persists, contact customer service.
Forward depth camera error	Automatically pause autonomous task	Forward depth camera no data	<ol style="list-style-type: none">1. Reboot the machine.2. Restart the autonomous task.3. If issue persists, contact customer service.
Right depth camera error	Automatically pause autonomous task	Right depth camera no data	<ol style="list-style-type: none">1. Reboot the machine.2. Restart the autonomous task.3. If issue persists, contact customer service.
IMU error	Automatically pause autonomous task	IMU no data	<ol style="list-style-type: none">1. Reboot the machine.2. Restart the autonomous task.3. If issue persists, contact customer service.
Controller error 1	Automatically pause autonomous task	Controller internal communication error	<ol style="list-style-type: none">1. Reboot the machine.2. Restart the autonomous task.3. If issue persists, contact customer service.
Controller error 2	Automatically pause autonomous task	Controller internal communication error	<ol style="list-style-type: none">1. Reboot the machine.2. Restart the autonomous task.3. If issue persists, contact customer service.
Controller error 3	Automatically pause autonomous task	Controller internal communication error	<ol style="list-style-type: none">1. Reboot the machine.2. Restart the autonomous task.3. If issue persists, contact customer service.



Handle communication interrupt

Automatically pause autonomous task

Handle communication interrupted

1. Reboot the machine.
2. Restart the autonomous task.
3. If issue persists, contact customer service.

9 Decommissioning and disposal



ATTENTION

It is the responsibility of the i-walk owner to dispose of the product responsibly.

At the end-of-life the i-walk still contains valuable resources and needs to be disposed of according to your local laws and regulations regarding recycling of electrical equipment.



Before disposal please:

1. Remove the battery for separate disposal, see section 6.13.1.

TIP:

Alternatively, keep the battery or batteries for use in another piece of i-team equipment.

2. Dispose all items according to your local laws and regulations.



10 Attachments

10.1 CE Certificate



EG/EC

KONFORMITÄTSERKLÄRUNG
DECLARATION OF CONFORMITY

Wir:

We: **Future Cleaning Technologies B.V., Hoppenkuil 27b, 5626 DD Eindhoven, Netherlands**

Erklären in alleiniger Verantwortung, das das Produkt:
Declare under our sole responsibility that the product:

i-walk

(Art der Maschine / Type of machine)

i-walk XL
und folgende / and following

(Modell – Seriennummer, Baujahr / Model – serial number, year of production)

auf das sich diese Erklärung bezieht, mit den folgenden Normen übereinstimm,
to which this declaration relates is in conformity with the following standards,

EN 60335-2-72:2012, EN 60335-2-89:2012, EN60335-1:2012+A11:2014+A13:2017+A1:
2019+A14:2019+A15:2021+A16:2023
EN IEC 61000-6-3:2021; EN IEC 61000-6-1:2019; EN 300 328 V2.2.2; ETSI EN 300 440
V2.2.1; ETSI EN 301 893 V2.1.1; ETSI EN 301 489-1 V2.2.3; ETSI EN 301 489-3 V2.3.2;
ETSI EN 301 489-17 V3.3.1; ETSI EN 301 908-2 V13.2.1; ETSI EN 301 908-13 V11.2.1
(2016-07); ETSI EN 301 489-52 V1.1.0 (2016-11);
EN IEC 62311: 2020 ETSI EN 300 220-2 V3.2.1

(Titel und/oder Nummer sowie Aufgabedatum der Norm(en) oder der anderen normativen Dokument(e)
(Title and/or number and data of issue of the standard(s) or other normative document(s))

gemäß die Bestimmungen der Richtlinien: follow the provisions of directives:

RED 2014/53/EU ROHS 2011/65/EU, EU 2015/863 Annex II, LVD. 2014/35/EU

Eindhoven, 25.09.2024

Frank van de Ven
Director

(Ort und Datum der Ausstellung)

(Name und Unterschrift oder gleichwertige
Kennzeichnung des Befugten)

(Place and Date of issue)

(name and signature or equivalent marking or
authorized person)



10.2 Specifications

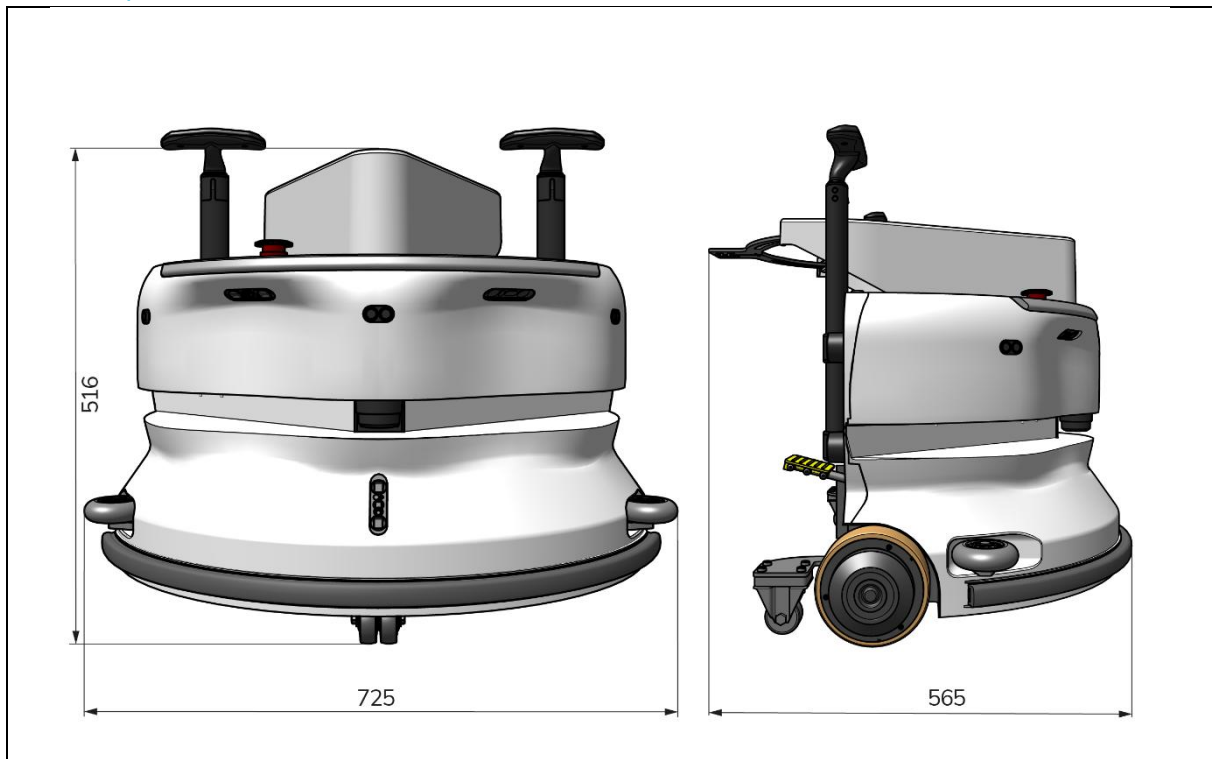

Figure 50

Theoretical performance:	1325 m ² /h
Battery Life:	~ 4 hours (1x i-power 9) ~ 7 hours (1x i-power 14)
Sensors:	2D LiDAR (x1) 3D TOF sensor (x3) Ultrasonic sensor (x3) Bumper strip (x1) Drive motor torque protection
Sensor range:	Up to 50 m @ 90% reflectivity Up to 15 m @ 15% reflectivity
Operational speed:	0.8 m/s
Weight:	22 kg
Dimensions (L x W x H):	725 x 565 x 516 mm
Features:	Obstacle avoidance (auto fill) Fleet management system Wifi connectivity Sim card



10.3 The i-Story

It's not just about cleaning machines.

It's about the well-being of people and the planet.

We are stoked about cleaning, thrilled about sustainability and wholeheartedly dedicated to keep on innovating.

We believe effective cleaning is more than just the removal of soil. It means ensuring the health and safety of people, while making the job easier, simpler, more efficient and even fun. It means consistent results all over the world, while protecting the world. And it means creating partnerships to grow our global force for better cleaning. After all, it takes a team.

The i-team.

Made Blue

By operating our products, your partners, clients and users lower the water footprint whilst contributing positively to the availability of water in the world. For this, we team up with Made Blue. Every day a i-walk is turned on, Made Blue simultaneously ensures someone else on the planet gets access to clean water. For every liter that the i-walk uses in operations, the i-team and Made Blue mirror clean drinking water in a developing country. The planet is a beautiful place with over 7 billion people. Humans need water to live, breathe, and enjoy their lives. Worldwide 2,7 billion people suffer from a shortage of drinking water. For 780 million people this situation is permanent, each year 3,5 million people die because of this. That's why Made Blue invests in projects in developing countries. We are a proud partner of Made Blue. Made Blue mirrors the water used by i-team to create clean water in developing countries. 1 liter for 1 liter.



MADE BLUE



Access to clean water for All.



i-team Professional b.v.

Hoppenkuil 27b, 5626 DD Eindhoven, The Netherlands

Telephone: +31402662400

Email: hello@i-teamglobal.com

Internet: www.i-teamglobal.com

