

1		2		3		4		5		6	
Revision	Description	Revised	Date								
A	FIRST RELEASE	CONNIE	02/Aug/2023								
A	SECOND RELEASE	YANG	16/Jul/2024								
										PAGE	2 / 27

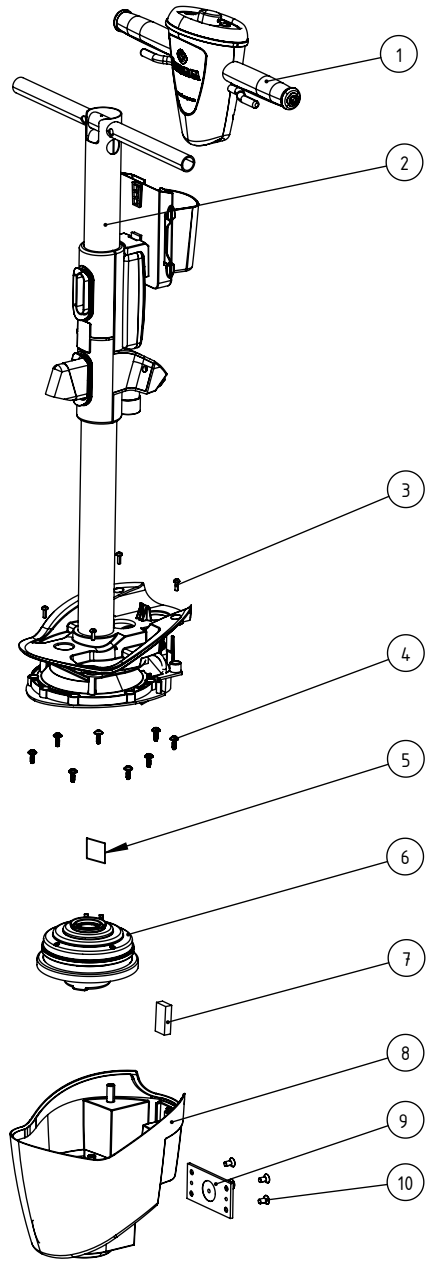

Item	P/N	Description	Qty.
	TU.IMOPXXL.230.0/U	ASSY TOP UNIT IMOPXXL	
1	S.72.1059.0U	ASSY CONTROL UNIT XXL BLUE BUTTON ALUMINUM BLA	1
2	S.72.1040.01U	ASSY INLET TUBE XXL	1
3	72.0121.1	SCREW M4X12, CROSS HEAD, STANDARD THREAD, SST	4
4	72.0026.0	SCREW WN 5451 50X14 EJOT DELTA PT	8
5	89.0467.2099.02	SERIAL NO. VACUUM MOTOR	1
6	S.72.1630.357	BRUSHLESS MOTOR COMPLETE I-MOP XXL PROTO	1
7	72.0051.0	MAGNET TOP UNIT 40X20X10MM [MCH 1416-1001-2044]	1
8	72.0111.357	MOTOR UNIT COVER [MCH 1416-1001-2118], Kleur: Grey	1
9	S.72.0031.2A	HINGE WELDING ASSY TOP UNIT 10.06+0.01/-0.01	1
10	72.0033.1	COUNTER SUNK HEAD CAP SCREW M6X12 WITH NYLOK GLUE	4

TOLERANCES UNSPECIFIED		REMARK: -		SMT-FCT DONGGUAN THE FRIENDLY FAMILY 东莞硕能塑胶模具有限公司 ASSEMBLY AND MOULDING OF CLEANING					
LINE	ANGLE	MATERIAL: -							
.xxx ±0.005	x ±2°	APPROVED	CHECKED	DISGND	REV.	A	PART NAME	IMOPXXLU.FCT.0C EXPLODED VIEW	
.xx ±0.05	.x ±1.5°			YANG	UNIT	mm	PART NO	IMOPXXLU.FCT.0C	SIZE
.x ±0.1	.xx ±1°				SCALE	1:1	PROJECT		A4
. ±0.2	.xxx ±0.5°	SHEET 1 OF 1		DATE		16/Jul/2024			
xx ±0.5									
xxx ±1									

1	2		3		4		5		6	
Revision	Description		Revised	Date					PAGE	3 / 27
A	First released version		Connie	01/Aug/2023						
A	SECOND RELEASE		YANG	16/Jul/2024						

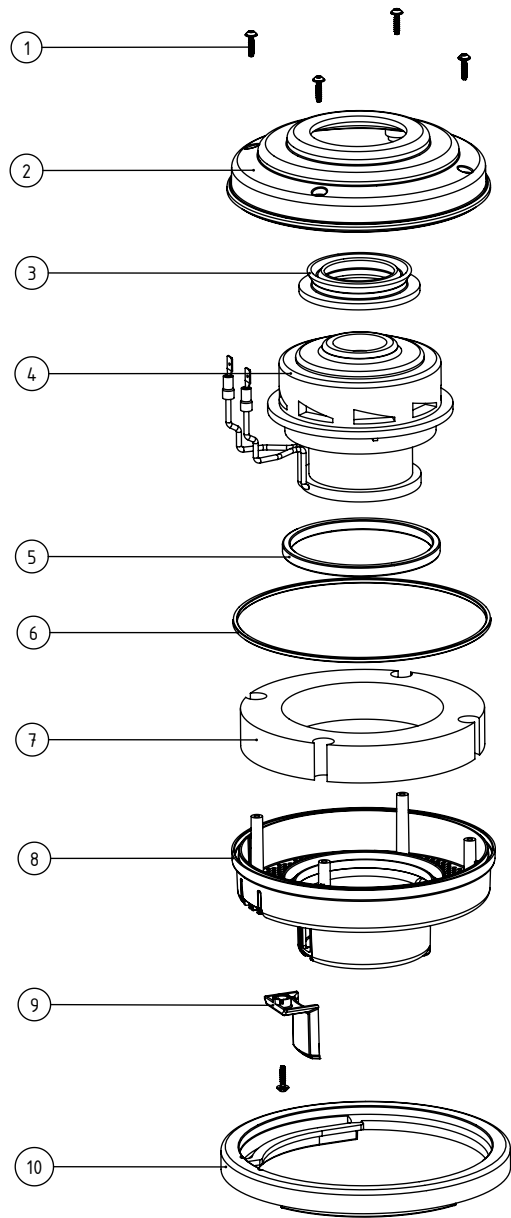

Item	P/N	Description	Qty.
	S.72.1630.357	BRUSHLESS MOTOR COMPLETE I-MOP XL&XXL PROTO	
1	72.0057.0	[MCH1011-101-101]SCREW WN 5451 25X10 EJOT DELTA PT	5
2	72.0631.357	BRUSHLESS MOTOR HOUSING COVER I-MOP XL&XXL	1
3	72.0633.0	BRUSHLESS MOTOR TOP SEAL IMOP XL&XXL ID56xOD36xT10.5	1
4	115.0310.1C	BRUSHLESS MOTOR 13-30V DC 60W/80W/100W GLUE DIPPING	1
5	115.0353.0	BRUSHLESS MOTOR SEAL BOTTOM ID66xOD73xT 4.8	1
6	72.0634.0	BRUSHLESS MOTOR HOUSING SEAL MIDDLE I-MOP XL&XXL ID115.4xOD119.5xT2	1
7	72.0639.0	SOUND-ABSORBING SPONGE Ø113xØ75xT18	1
8	72.0630.357	BRUSHLESS MOTOR HOUSING BASE I-MOP XL&XXL	1
9	115.0355.357	BRUSHLESS MOTOR CABLE COVER I-MOP LITE PROTO	1
10	72.0632.1	BRUSHLESS MOTOR HOUSING SEAL BOTTOM I-MOP XL&XXL	1

TOLERANCES AND DIMENSIONS (UNLESS OTHERWISE SPECIFIED)		MATERIAL:		 THE FRIENDLY FAMILY 东莞硕能塑胶模具有限公司 Dongguan Solid-CST Plastic Molding Co., Ltd 东莞市石碣镇新风西路99号 No.99 XinFeng West Road ShiJie Town DongGuan City China				
0.5-3mm	±0.1mm	COLOR:						
3-6mm	±0.1mm	TREATMENT:						
6-30mm	±0.2mm	APPROVED	CHECKED	DISGNE	REV.	R01	PART NAME	IMOPXXLU.FCT.0C EXPLODED VIEW
30-120mm	±0.3mm			YANG	UNIT	mm	PART NO	IMOPXXLU.FCT.0C
120-400mm	±0.5mm			16/Jul/2024	SCALE	1:1	PROJECT	
ANGLES	±1.0°							
HOLE Ø	±0.1mm							

1		2		3		4		5		6	
Revision	Description	Revised	Date								
A	FIRST RELEASE	CONNIE	01/Aug/2023								
A	SECOND RELEASE	YANG	16/Jul/2024								
										PAGE	4 / 27

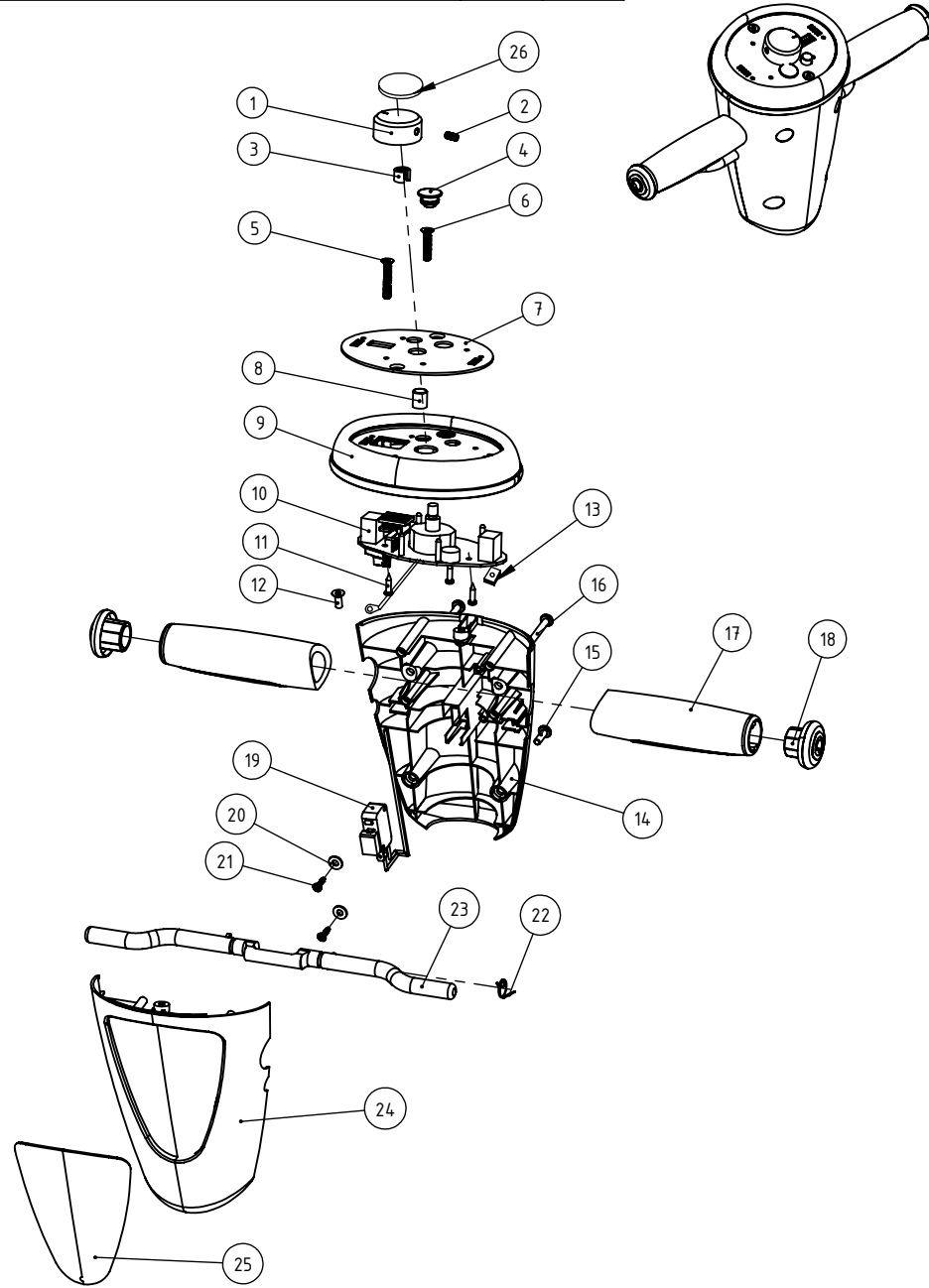

Item	P/N	Description	Qty.
	S.72.1059.0U	ASSY CONTROL UNIT XXL BLUE BUTTON ALUMINUM BLA	
1	72.0155.5/0	TURNING BUTTON NODIC OXIDATION M:AL BLACK	1
2	00.0115.0	HEXAGON SOCKET SET SCREW M4 X 8	1
3	72.0272.0	FIXATION INSERT TURNING BUTTON	1
4	72.0225.0/A	RUBBER BLOCK WATER SAVE ADJUSTMENT HOLE [A]	1
5	72.0273.0	M4X20 COUNTERSUNK SCREW STAINLESS STEEL	1
6	72.0273.1	M4X25 COUNTERSUNK SCREW STAINLESS STEEL	1
7	89.0467.2222.04	AL. STICKER IMOPXXL	1
8	72.0203.0	WATER SAVE BUTTON	1
9	72.0061.2F	TOP HOUSING CONTROL UNIT COLOR: WHITE + TIMER TIHICKEN RUBBER RING	1
10	72.0651.0	TOP PCB IMOP WITH GYROSCOPE TWO SPEED	1
11	85.1008.1	SCREW M3 X12 CROSSHEAD SELFTAPPING BL-NI, SST	3
12	00.0002.7	SCREW 4 X 10	1
13	72.0263.0	SWITCH WIRE CLAMP, Kleur: Black	1
14	72.0059.2C	REAR HOUSING CONTROL UNIT Color: White [C]	1
15	72.0121.1	SCREW M4X12, CROSS HEAD, STANDARD THREAD, SST	2
16	72.0122.1	SCREW M4X35CROSS HEAD, STANDARD THREAD, SST	2
17	72.1230.357	HANDLE GRIP XXL, Kleur: Grey.357 (P431C)	2
18	72.1229.797	END CAP WITH LOGO M20X1.5, Kleur : Blue.797 (P312C)	2
19	S.72.0060.3	ASSY POWER SWITCH CONTROL UNIT	1
20	72.0271.0	PLASTIC WASHER 9x4x1mm	2
21	72.0057.0	MCH011-101-101 SCREW WN 5451 25X10 EJOT DELTA PT	2
22	72.0228.1	SPRING_SWITCH LEVER DIA.0.8MM (Ver.1)	1
23	72.0063.797	HANDLE CONTROL UNIT [MCH 1416-1001-2065], Kleur	1
24	72.0064.2C	FRONT HOUSING CONTROL UNIT Color: White [C]	1
25	S.89.0467.2099.01P	ASSY AL.PLATE PRO WITH CLIP +3M TAPES [HANDLE]	1
26	89.0469.2099.24	REMOVE STICKER ON THE SWITCH	1

TOLERANCES UNSPECIFIED		REMARK:		<p style="text-align: center;">SMT-FCT DONGGUAN THE FRIENDLY FAMILY 东莞硕能塑胶模具有限公司 ASSEMBLY AND MOULDING OF CLEANING</p>			
LINE	ANGLE	-					
.xxx ±0.005	x ±2°	-		APPROVED	CHECKED	DISGNE	REV.
.xx ±0.05	.x ±1.5°	-				YANG	UNIT
.x ±0.1	.xx ±1°	-					mm
. ±0.2	.xxx ±0.5°	-					SCALE
xx ±0.5		-					PROJECT
xxx ±1		-					SIZE
SHEET 1 OF 1		DATE		16/Jul/2024		A4	

1	2	3	4	5	6
Revision	Description	Revised	Date	PAGE 5 / 27	
A	FIRST RELEASE	CONNIE	01/Aug/2023		
A	SECOND RELEASE	YANG	16/Jul/2024		

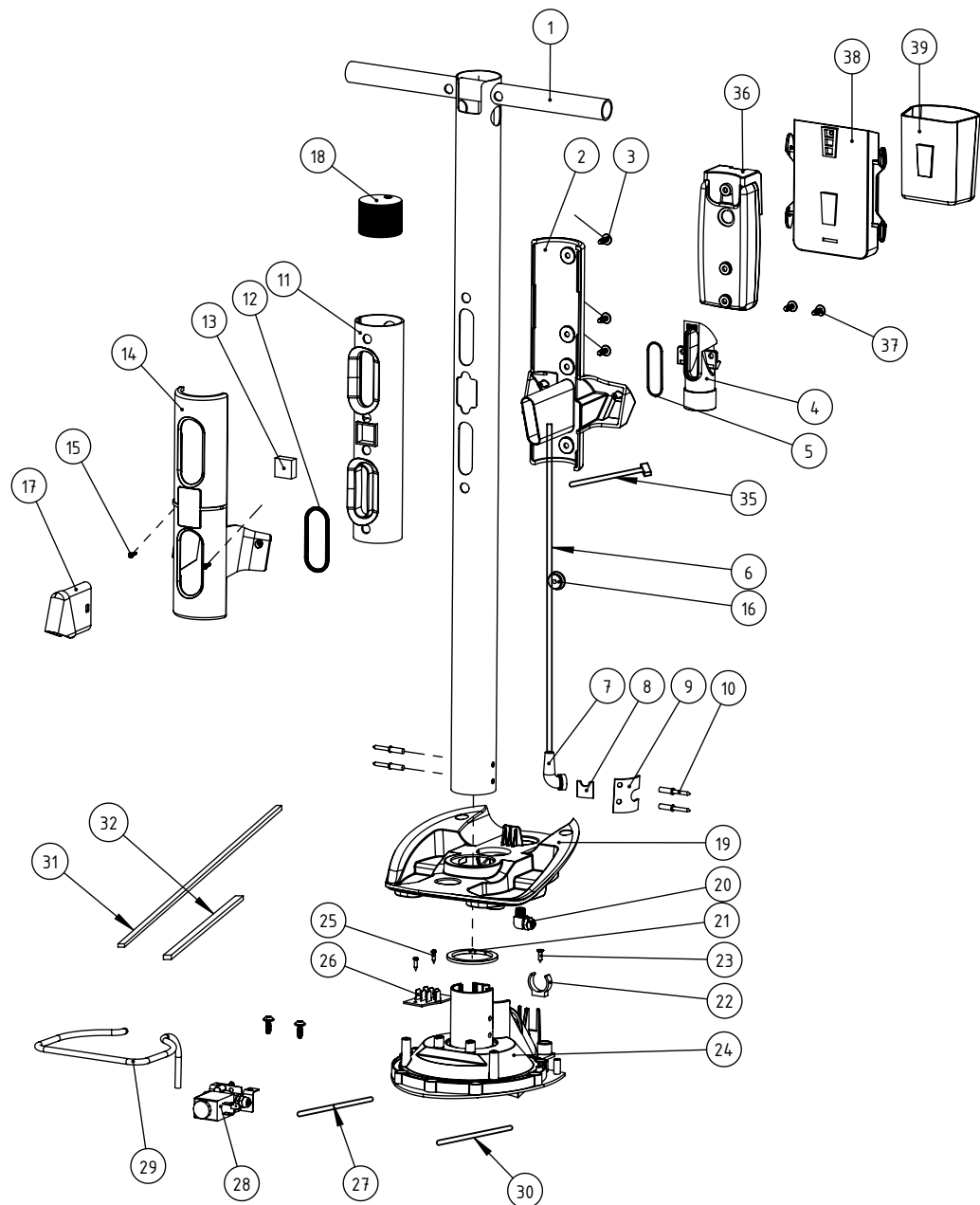

Item	P/N	Description	Qty.
	S.72.1040.01U	ASSY INLET TUBE XXL	
1	S.72.1041.0B	ASSY INLET TUBE WELDING I-LINK IMOPXXL	1
2	72.1055.357A	TANK HOLDER REAR WITH GROOVE I-LINK	1
3	72.0450.0	SCREW WN 5451 5.0X18 EJOT DELTA PT	4
4	72.0056.357A	STRETCH HOSE CONNECTOR [MCH 1416-1001-2199] Kleur Grey	1
5	72.0296.0	GASKET FOR HOSE CONNECTOR	1
6	S.72.0039.3	ASSY UTP CABLE (PVC+FIBRE) 10P AVIATION PLUG I-LINK	1
7	72.0042.0	POWER CABLE GUIDING RUBBER [MCH 1416-1001-2187]	1
8	72.0268.0	SEALING RUBBER SHEET AL TUBE	1
9	72.0267.0	SEALING PRESSUR PLATE	1
10	72.0119.0	RIVET WITH DIA. 5MM & LENGTH 10 MM	4
11	72.0052.0A	DIRT COMPARTMENT SEAL I-LINK	1
12	72.0160.0	O RING WIRE DIA.3MM, OD46MM	1
13	72.0053.0	MAGNET TOP UNIT SMALL 20X20X10MM [MCH 1416-1001-2172]	1
14	72.0054.357	TANK HOLDER FRONT [MCH 1416-1001-2196], Kleur: Grey .357	1
15	72.0057.0	[MCH011-101-101]SCREW WN 5451 25X10 EJOT DELTA PT	2
16	72.0573.0	RUBBER RING SEAL I-LINK WIRING CABLE	1
17	72.0163.1/996	TRANSPARENT PLASTIC DEFLECTOR DIRTY TANK	1
18	72.0038.1	END CAP INLET TUBE ID=5.1MM I-LINK	1
19	S.72.0113.357D	ASSY MOTOR UNIT TOP WITHCHROMING COUPLING	1
20	72.0049.1	ANGLE METAL CONNECTOR	1
21	72.0044.1	MOTOR UNIT FRAME RUBBER [ID42.5MM]	1
22	72.0247.0/A	CLIP PLASTIC IN WHITE Width:7MM	1
23	72.0240.0	COUNT SUNK SCREW M3.5X13 PHILPS HEAD	1
24	72.0114.357	MOTOR UNIT FRAME [MCH 1416-1001-2122], Kleur: Grey .357	1
25	85.1008.1	SCREW M3 X12 CROSSHEAD SELFTAPPING BL-NI,SST	2
26	72.0182.0/A	PCB MAGNETIC VALVE & VAC MOTOR CONNECTION [A]	1
27	72.0127.0	187 TERMINAL + WIRE 14AWG, RED, L=280mm, 250 TERMINAL	1
28	S.72.0026.6	ASSY MAGETIC VALVE PARKER	1
29	72.0022.2	WATER CHANNEL DIA.6MM L:225mm	1
30	72.0128.0	187 TERMINAL + WIRE 14AWG, BLACK, L=280mm, 250 TERMINAL	1
31	72.0209.0B	SEALING GASKET EVA 3X1.5X593MM [3M9448HKB]	1
32	72.0210.0B	SEALING GASKET EVA 4X2.5X150MM [3M9448HKB]	1
33	00.0117.0 NO SHOW	GULE ND401	1
34	72.0232.0 NO SHOW	THREAD SEALING ADHESIVE	0.02
35	72.0576.0	CABLE 3P 20AWG I-LINK L=400	1
36	S.72.0463.357	I-LINK IOT PCB BOX BASE	1
37	72.0026.0	SCREW WN 5451 50X14 EJOT DELTA PT	12
38	115.0315.357	MOBILE PHONE POCKET	1
39	72.0557.357	I-DOSE RECYCLING BIN MICROBAN ANTIBACTERIAL	1

TOLERANCES UNSPECIFIED		REMARK:		<p style="text-align: center;">SMT-FCT DONGGUAN THE FRIENDLY FAMILY 东莞硕能塑胶模具有限公司 ASSEMBLY AND Moulding of CLEANING</p>			
LINE	ANGLE	-					
.xxx ±0.005	x ±2°	MATERIAL: -		APPROVED	CHECKED	DISGNE	REV.
.xx ±0.05	.x ±1.5°						A
.x ±0.1	.xx ±1°						mm
. ±0.2	.xxx ±0.5°						UNIT
xx ±0.5							SCALE
xxx ±1							1:1
SHEET 1 OF 1		DATE		16/Jul/2024		PROJECT	
				YANG		A4	

1		2		3		4		5		6	
Revision	Description	Revised	Date								
A	FIRST RELEASE	CONNIE	02/Aug/2023								
A	SECOND RELEASE	YANG	16/Jul/2024								

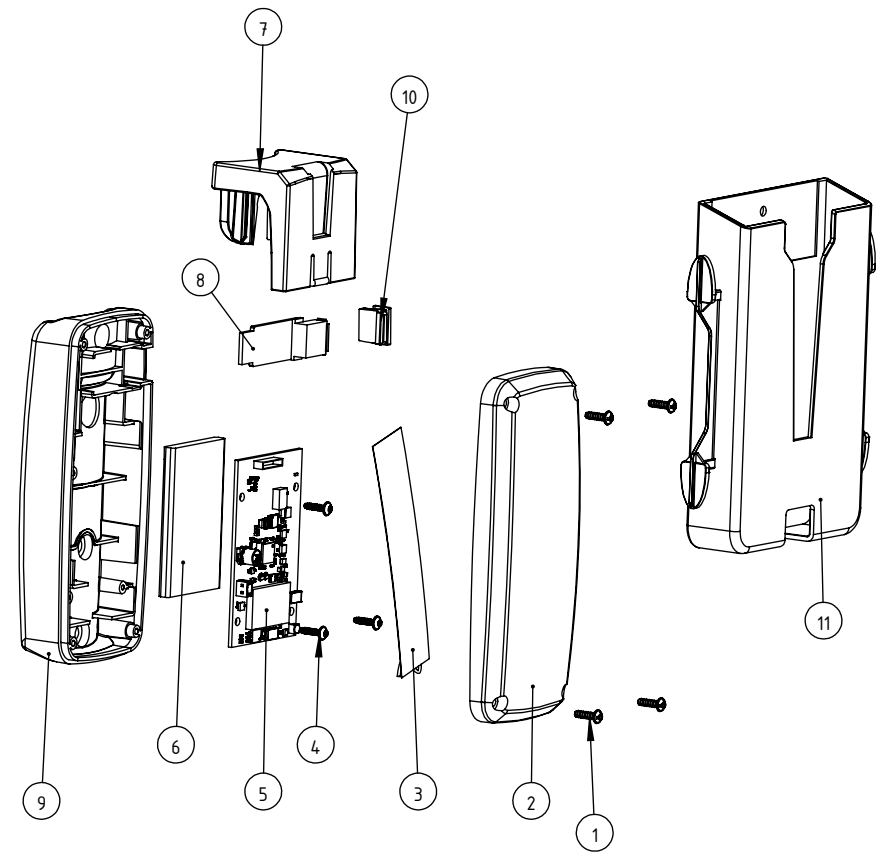

Item	P/N	Description	Qty.
	S.72.0463.357A	I-LINK IOT PCB BOX ASSY WITH (USB PCB/LINK/PHONEHOLDER)	
1	115.0011.3	EJOT PT SCREW WN 5451 30X10 ANTI-THEFT 4	4
2	72.0464.357	I-LINK IOT PCB BOX COVER WITH PRINT	1
3	72.0492.0	TOOLSENSE ANTENNA WIRE LENGTH 10CM	1
4	72.0057.0	SCREW WN 5451 25X10 EJOT DELTA PT	3
5	72.0490.0B	TOOLSENSE PCB (Version:5)	1
6	72.0491.0	TOOLSENSE Lipo BATTERY 3.7V,1200 mAh WIRE LENGTH 25CM2P 1.25	1
7	72.0572.357	MOBILE PHONE HOLDER HOOK	1
8	S.72.0619.0	USB CHARGING PCB CABLE ASSY OUTPUT DC5V	1
9	72.0463.357	I-LINK IOT PCB BOX BASE	1
10	72.0666.0	USB INTERFACE RUBBER PLUG	1
11	S.115.0315.357	ASSY I-DOSE PHONE HOLDER	1
12	115.0318.0 NO SHOW	USB phone charging cable 3 in 1	1
13	S.72.0582.0 NO SHOW	CABLE I-LINK PCB JST 12P+2P 2.0 L=100MM	1

TOLERANCES UNSPECIFIED		REMARK:		SMT-FCT DONGGUAN THE FRIENDLY FAMILY 东莞硕能塑胶模具有限公司 ASSEMBLY AND MOULDING OF CLEANING			
LINE	ANGLE	-					
.xxx ±0.005	x ±2°	-		APPROVED	CHECKED	DISGND	REV.
.xx ±0.05	.x ±1.5°	-					A
.x ±0.1	.xx ±1°	-					mm
. ±0.2	.xxx ±0.5°	-					UNIT
xx ±0.5		-					mm
xxx ±1		-					SCALE
SHEET 1 OF 1		DATE		16/Jul/2024		SCALE 1:1	

1		2		3		4		5		6	
Revision	Description			Revised	Date						
A	FIRST RELEASE			CONNIE	01/Aug/2023						
A	SECOND RELEASE			YANG	16/Jul/2024						

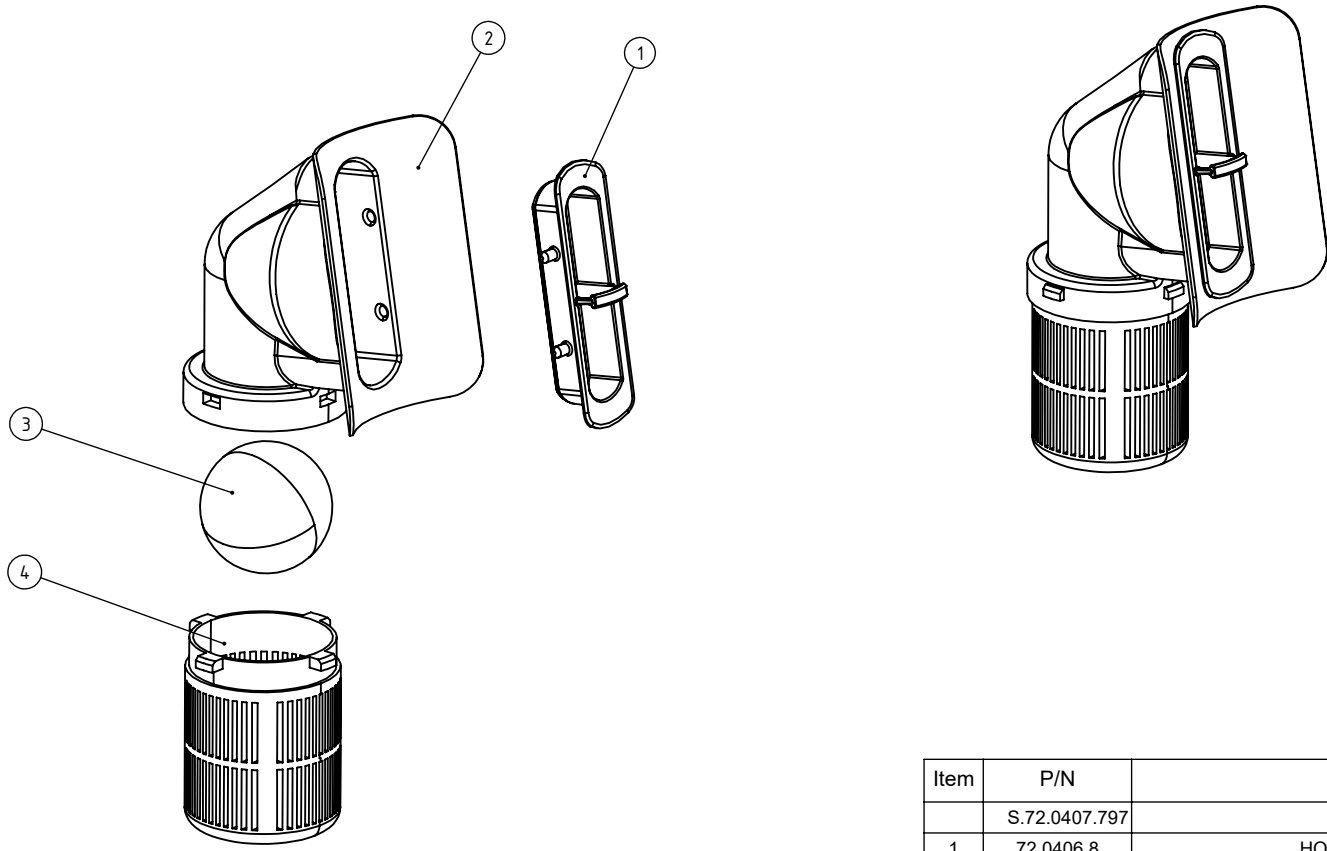

Item	P/N	Description	Qty.
	S.72.0407.797	ASSY FLOAT BALL	
1	72.0406.8	HOUSING SUPPORT YELLOW P122C	1
2	72.0408.0A	FLOAT BALL HOUSING	1
3	72.0407.797	BLOCKING BALL 35MM BLUE 16G	1
4	72.0405.8A	FLOAT BALL CAGE YELLOW P122C	

TOLERANCES UNSPECIFIED		REMARK: -		SMT-FCT DONGGUAN THE FRIENDLY FAMILY 东莞硕能塑胶模具有限公司 ASSEMBLY AND MOULDING OF CLEANING			
LINE	ANGLE	MATERIAL: -					
.xxx ±0.005	x ±2°	APPROVED	CHECKED	DISGND	REV.	A	PART NAME
.xx ±0.05	.x ±1.5°			YANG	UNIT	mm	PART NO
.x ±0.1	.xx ±1°				SCALE		PROJECT
. ±0.2	.xxx ±0.5°						
xx ±0.5							
xxx ±1							
SHEET OF		DATE		16/Jul/2024		SIZE	
						A4	

Revision	Description	Revised	Date	PAGE	8 / 27
A	FIRST RELEASE	Connie	01/Aug/2023		
A	SECOND RELEASE	YANG	16/Jul/2024		

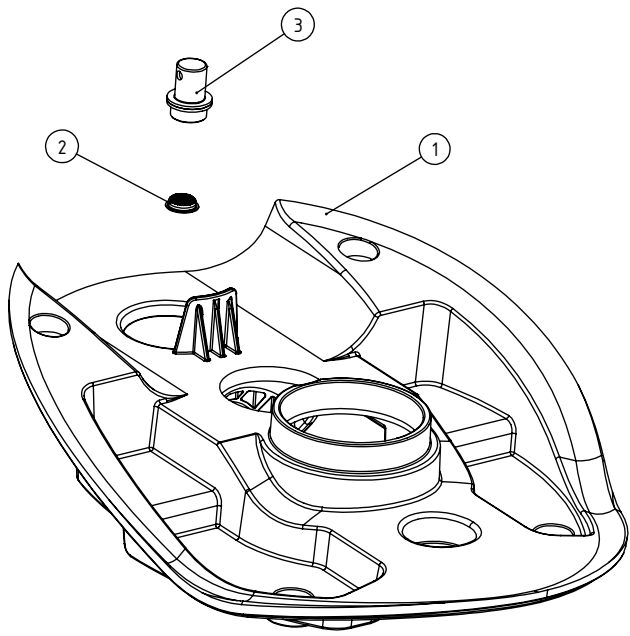

Item	P/N	Description	Qty.
	S.72.0113.357C	ASSY MOTOR UNIT TOP WITH CHROMING COUPLING	
1	72.0113.357A	MOTOR UNIT TOP	1
2	72.0413.0A	METAL GREASE FILTER Ø0.6MM HOLES	1
3	72.0412.0B	WATER INLET COUPLING CHROMING+RUBBER WASHER	1

TOLERANCES AND DIMENSIONS (UNLESS OTHERWISE SPECIFIED)		MATERIAL:		 东莞硕能塑胶模具有限公司 Dongguan Solid-CST Plastic Molding Co., Ltd 东莞市石碣镇新风西路99号 No.99 XinFeng West Road ShiJie Town DongGuan City China					
0.5-3mm	±0.1mm	COLOR:							
3-6mm	±0.1mm	TREATMENT:							
6-30mm	±0.2mm	APPROVED	CHECKED	DISGNE	REV.	-	PART NAME	IMOPXXLU.FCT.0C EXPLODED VIEW	
30-120mm	±0.3mm			YANG	UNIT	mm	PART NO	IMOPXXLU.FCT.0C	
120-400mm	±0.5mm			16/Jul/2024	SCALE	1:1	PROJECT		
ANGLES	±1.0°								
HOLE Ø	±0.1mm								

A
B
C
D

A
B
C
D

1	2	3	4	5	6
Revision	Description	Revised	Date	PAGE 9 / 27	
A	FIRST RELEASE	CONNIE	02/Aug/2023		
A	SECOND RELEASE	YANG	16/Jul/2024		

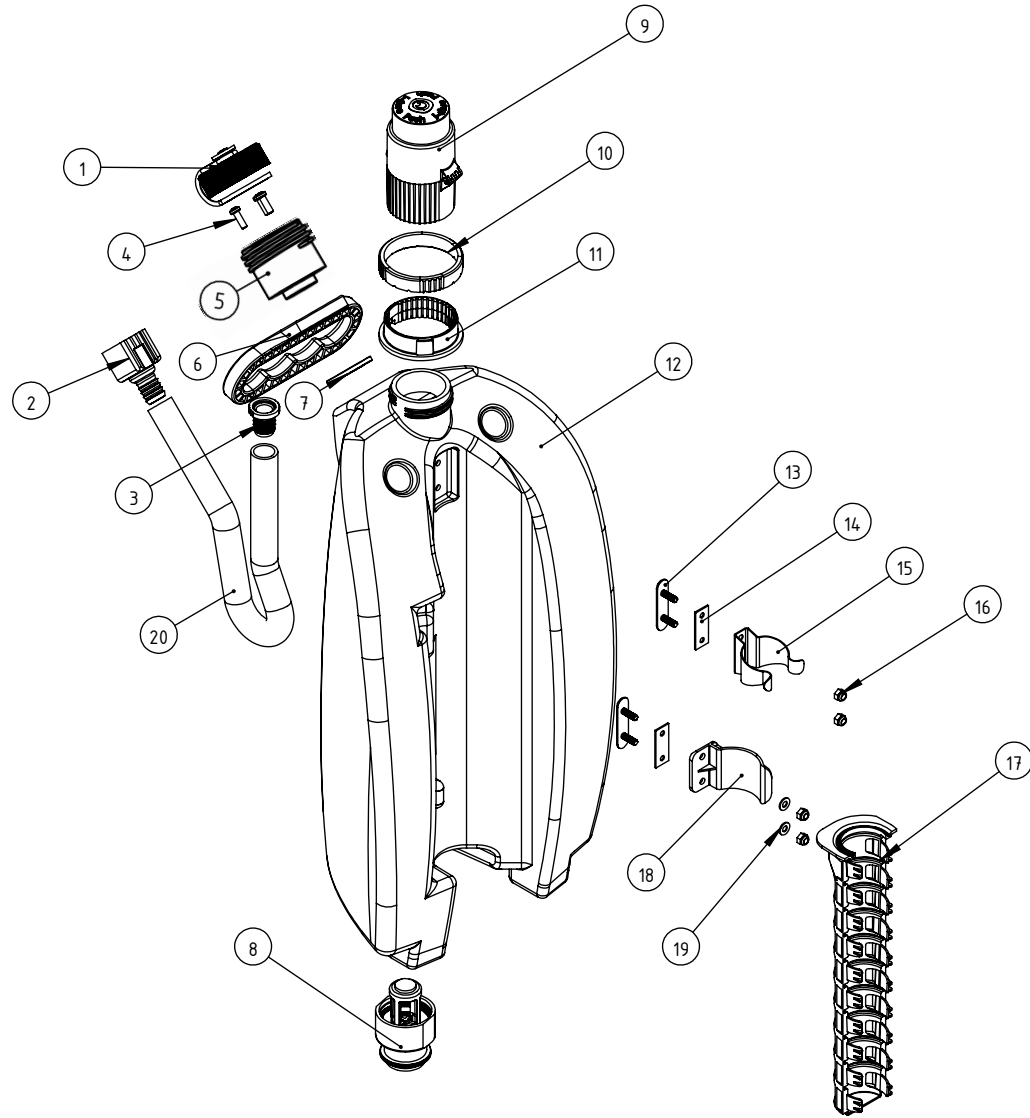

Item	P/N	Description	Qty.
	P.72.1081.2	I-LINK IOT PCB BOX ASSY WITH (USB PCB/ILINK/PHONEHOLDER)	
1	S.72.0264.8	CAP WITHOUT HOLE Color: YELLOW	1
2	72.0550.357	FILLING HOSE CONNECTOR HOPP	1
3	72.0551.357	FILLING HOSE CONNECTOR STOPPER	1
4	00.0121.2	SCREW M4X12 CROSSHEAD MACHINE STAINLESS	3
5	72.0484.357	I-DOSE FILLING HOLE ADAPTOR BLUE [P312C]	1
6	72.0489.357	SOLUTION TANK LIFTING HANDLE GREY P431C	1
7	72.0486.0	I-DOSE FILLING HOLE ADAPTOR FIXING PLATE	1
8	S.72.0085.357	WATER COUPLING VERSION	1
9	S.72.0433.0	ASSY I-DOSE INJECTOR HOUSING	1
10	72.0480.357	I-DOSE COLOR CODING RING +PRINT	1
11	72.0481.357	I-DOSE COLOR CODING FLANGE BAS	1
12	72.1081.2	LOGO PRINT+SOLUTION TANK IMOP XXL DOSE	1
13	72.0253.0	HOLDER PLATE CLIP CLEAN TANK	2
14	72.0290.0	RUBBER CUSHION FOR METAL CLIP	2
15	72.0288.0	METAL CLIP CLEAN TANK	1
16	72.0261.0	NUT M4 NYLON STAINLESS	4
17	72.0431.0	DOSE CUP HOLDER	1
18	72.0430.0	TUBE CLIP	1
19	00.0106.1	WASHER 9X4X0.8MM Stainless	2
20	72.0549.0	FILLING HOSE ID 13xOD 17 PP SPRING WIRE FORTIFIED LENGTH 50CM	1

TOLERANCES UNSPECIFIED

LINE	ANGLE
.xxx ±0.005	x ±2°
.xx ±0.05	.x ±1.5°
.x ±0.1	.xx ±1°
. ±0.2	.xxx ±0.5°
xx ±0.5	
xxx ±1	

REMARK: -

MATERIAL: -

APPROVED

CHECKED

DISGNE

REV. A

UNIT mm

SCALE 1:1

DATE 16/Jul/2024

SMT-FCT DONGGUAN
THE FRIENDLY FAMILY
 东莞硕能塑胶模具有限公司
ASSEMBLY AND MOULDING OF CLEANING

PART NAME	IMOPXXLU.FCT.OC EXPLODED VIEW	PROJ	
PART NO	IMOPXXLU.FCT.OC	SIZE	A4

1		2		3		4		5		6	
Revision	Description			Revised	Date						
A	FIRST RELEASE			CONNIE	01/Aug/2023	PAGE 10 / 27					
A	SECOND RELEASE			YANG	16/Jul/2024						

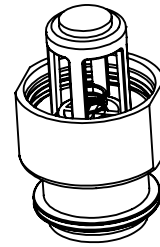
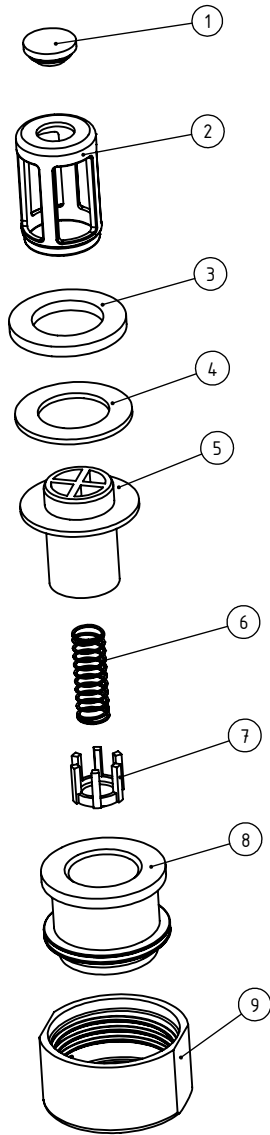

Item	P/N	Description	Qty.
	S.72.0085.357	WATER COUPLING VERSION	
1	72.0192.6	RUBBER BLOCK FILTER	1
2	72.0085.0	WATER COUPLING FILTER[MCH 1416-1001-2188]	1
3	72.0192.5	RUBBER GASKET ID 19mm, OD31mm, T=1.5mm	1
4	72.0192.5/A	RUBBER GASKET ID 19mm, OD31mm, T=3mm	1
5	72.0192.2/375A	HOUSING OF VALVE[GREY(A)]	1
6	72.0192.3/A	SPRINGWATER COUPLING (A)	1
7	72.0192.4/357A	VALVE WATER COUPLING, GREY (A)	1
8	72.0192.1	HOUSING WATER COUPLING	1
9	72.0289.0/357	METAL CAP WATER COUPLING, GREY	1

TOLERANCES UNSPECIFIED		REMARK: -		SMT-FCT DONGGUAN THE FRIENDLY FAMILY 东莞硕能塑胶模具有限公司 ASSEMBLY AND MOULDING OF CLEANING					
LINE	ANGLE	MATERIAL: -							
.xxx ±0.005	x ±2°	APPROVED	CHECKED	DISGND	REV.	A	PART NAME	IMOPXXLU.FCT.0C EXPLODED VIEW	
.xx ±0.05	.x ±1.5°			YANG	UNIT	mm	PART NO	IMOPXXLU.FCT.0C	SIZE
.x ±0.1	.xx ±1°				SCALE		PROJECT		A4
. ±0.2	.xxx ±0.5°								
xx ±0.5									
xxx ±1									
SHEET OF	DATE			16/Jul/2024					

1		2		3		4		5		6	
Revision	Description	Revised	Date								
A	FIRST RELEASE	CONNIE	01/Aug/2023								
A	SECOND RELEASE	YANG	16/Jul/2024								
										PAGE	11 / 27

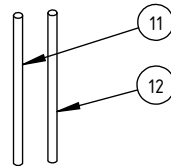
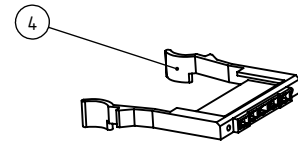
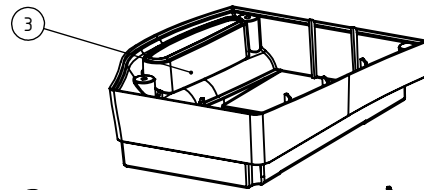
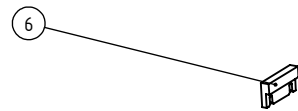
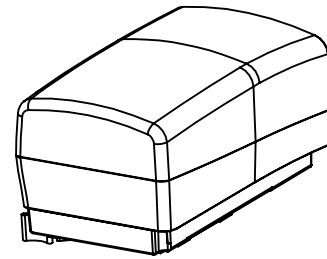
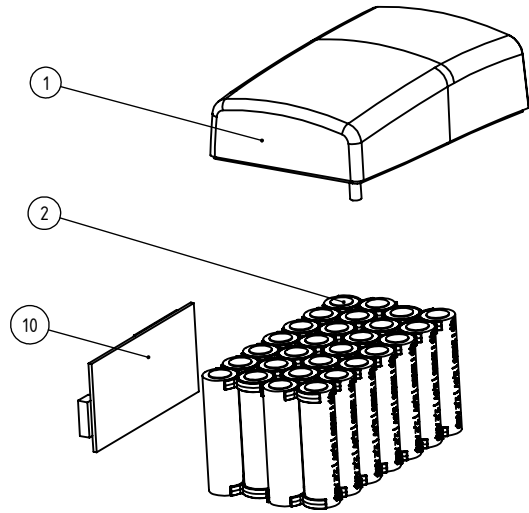

Item	P/N	Description	Qty.
	S.72.0074.357BSRA	ASSY BATTERY PACK GREY [LEFT] BMS 14Ah [FR] W/O FU	
1	72.0078.357R	BATTERY PACK HOUSING TOP LEFT [FIRE RESISTANT]	1
2	72.0131.1/C	BATTERY PACK CELLS WITH BMS [14Ah] [W/O FUSE]	1
3	72.0074.357R	BATTERY PACK HOUSING BOTTOM LEFT GREY [FIRE RESTANT]	1
4	72.1075.797	BATTERY CONNECTOR FEMALE, BLUE, LEFT [P312C]	1
5	72.0057.0	[MCH011-101-101]SCREW WN 5451 25X10 EJOT DELTA PT	6
6	72.0218.0	LIMITATION BLOCK FEMALE CONNECTOR	1
7	72.0170.0 NO SHOW	BUBBLE WRAP BAG 250x210	1
8	89.0469.2099.05 NO SHOW	SERIAL NO. BATTERY (C)	1
9	89.0469.2099.40 NO SHOW	STICKER SAFETY ADVISE FOR BATTERY LEFT BMS 3400mAh	1
10	72.0284.0A	BMS BOARD I-POWER 9&14UPLIHER MODEL 7SZYJH-D120	1
11	72.0129.0A	BATTERY CONNECTOR + WIRES 14AWG, RED, L=290 TYCO TERMINAL 96328-1	1
12	72.0130.0A	BATTERY CONNECTOR + WIRES 14AWG, RED, L=290 TYCO TERMINAL 96328-1	1

TOLERANCES UNSPECIFIED		REMARK:		SMT-FCT_DONGGUAN THE FRIENDLY FAMILY 东莞硕能塑胶模具有限公司 ASSEMBLY AND MOULDING OF CLEANING			
LINE	ANGLE	-					
.xxx ±0.005	x ±2°	MATERIAL: -		APPROVED	CHECKED	DISGNE	REV.
.xx ±0.05	.x ±1.5°					YANG	UNIT
.x ±0.1	.xx ±1°					mm	SCALE
. ±0.2	.xxx ±0.5°					1:1	PROJECT
xx ±0.5						16/Jul/2024	SCALE
xxx ±1							SCALE
SHEET OF		DATE		16/Jul/2024		SCALE	
				1:1		PROJECT	
				A4			

1		2		3		4		5		6	
Revision	Description	Revised	Date					PAGE	12 / 27		
A	FIRST RELEASE	CONNIE	01/Aug/2023								
A	SECOND RELEASE	YANG	16/Jul/2024								

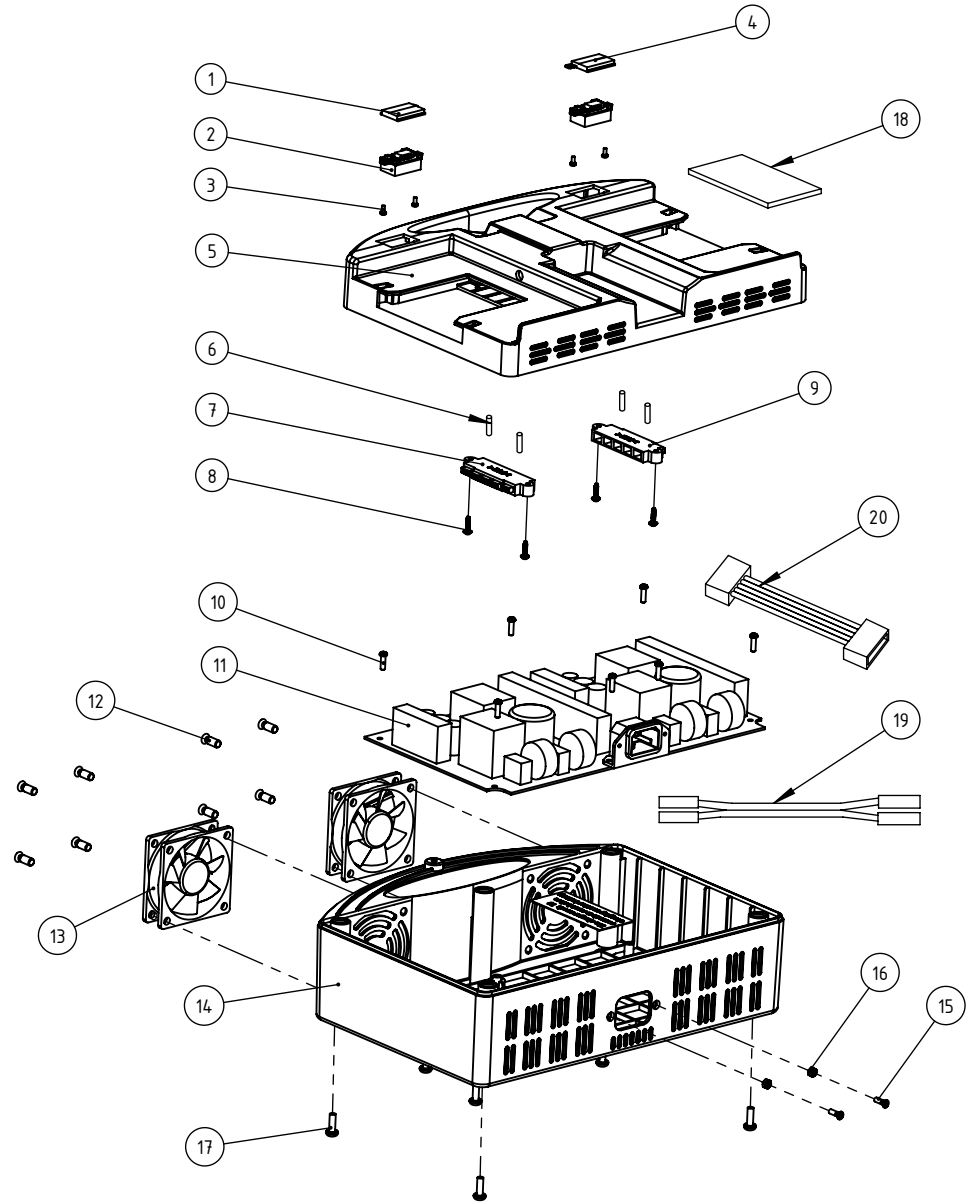

Item	P/N	Description	Qty.
	S.72.0344.0	IMOP BATTERY MCU CHARGER 3 PIN [9A] PSE+CB	
1	72.0275.0	TRANSPARENT COVER VOLTAGE DISPLAY LEFT	1
2	72.0174.0/B	VOTAGE DISPLAY WITH BAR	2
3	72.0328.0	SCREW M2X 5 CROSS HEAD SELF TAPPING	4
4	72.0275.1	TRANSPARENT COVER VOLTAGE DISPLAY RIGHT	1
5	72.0187.2R	NEW CHARGER TOP HOUSING WHITE [FIRE RESISTANT]	1
6	85.0050.1A	ALIGNMENT PIN Ø1.5X7 STAINLESS STEEL	4
7	72.0068.357	BATTERY CONNECTOR MALE Left:Blue, Right:Grey K1e	1
8	72.0057.0	[MCH 011-101-101] SCREW WN 5451 25X10 EJOT DELTA PT	4
9	72.0068.797	BATTERY CONNECTOR MALE, Left Blue Right:Grey,K1e	1
10	72.0353.0	SCREW M3x10 CROSSHEAD SELFTAPED	7
11	72.0106.0-9A	CHARGE UNIT 9A	1
12	72.0357.0	COUNTER SUNK SCREW M5x10	8
13	72.0351.0	FANS	2
14	72.0188.357-9A	CHARGER BOTTOM HOUSING GREY 9A	1
15	66.0301.0	COUNTER SUNK SCREW M3X15	2
16	20.0031.5	NUT M3 NYLON	2
17	00.0121.0	SCREW ST4 X 9.3 CROSSHEAD SELFTAPED BL-NI	6
18	89.0469.2089.02	CHARGER PROGRAM STICKER [70X30MM]	1
19	72.0350.0	TWO MALE TERMINALS WITH RED & BLACK LINES	2
20	72.0350.1	LINES + PIN	2

TOLERANCES UNSPECIFIED		REMARK:		<p style="text-align: center;">SMT-FACT DONGGUAN THE FRIENDLY FAMILY 东莞硕能塑胶模具有限公司 ASSEMBLY AND MOULDING OF CLEANING</p>			
LINE	ANGLE	-					
.xxx ±0.005	x ±2°	MATERIAL: -		APPROVED	CHECKED	DISGNE	REV.
.xx ±0.05	.x ±1.5°					YANG	A
.x ±0.1	.xx ±1°					UNIT	mm
. ±0.2	.xxx ±0.5°					SCALE	
xx ±0.5						DATE	16/Jul/2024
xxx ±1						PROJECT	
SHEET 1 OF 1		DATE		16/Jul/2024		SCALE	
						PROJECT	
						PROJECT	

1	2		3		4		5		6	
Revision	Description		Revised	Date						
A	FIRST RELEASE		CONNIE	01/Aug/2023						
A	SECOND RELEASE		YANG	16/Jul/2024						

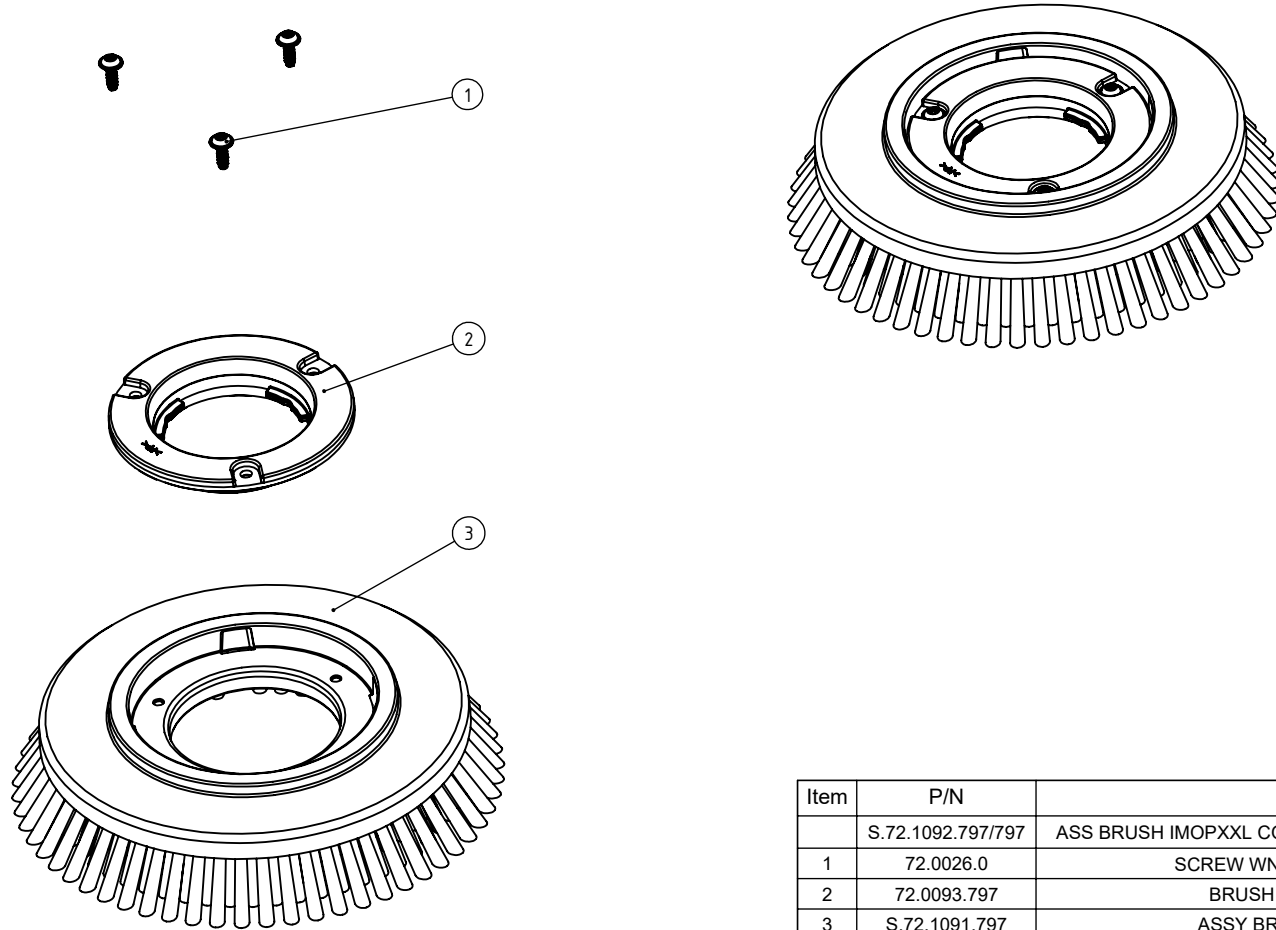

Item	P/N	Description	Qty.
	S.72.1092.797/797	ASS BRUSH IMOPXXL COMPLETE BLUE BRISTLE, BLUE LOCKER	
1	72.0026.0	SCREW WN 5451 50X14 EJOT DELTA PT	3
2	72.0093.797	BRUSH LOCKER BLUE (P312C)	1
3	S.72.1091.797	ASSY BRUSH DISC BLUE (P312C) XXL	1

TOLERANCES UNSPECIFIED		REMARK: -		SMT-FCT DONGGUAN THE FRIENDLY FAMILY 东莞硕能塑胶模具有限公司 ASSEMBLY AND MOULDING OF CLEANING			
LINE	ANGLE	MATERIAL: -					
.xxx ±0.005	x ±2°	APPROVED	CHECKED	DISGND	REV.	A	PART NAME
.xx ±0.05	.x ±1.5°			YANG	UNIT	mm	IMOPXXLU.FCT.0C EXPLODED VIEW
.x ±0.1	.xx ±1°				SCALE		PART NO
. ±0.2	.xxx ±0.5°						IMOPXXLU.FCT.0C
xx ±0.5							PROJECT
xxx ±1							SIZE
SHEET OF		DATE		16/Jul/2024		A4	

Revision	Description	Revised	Date
A	FIRST RELEASE	CONNIE	07/Aug/2023
A	SECOND RELEASE	YANG	16/Jul/2024

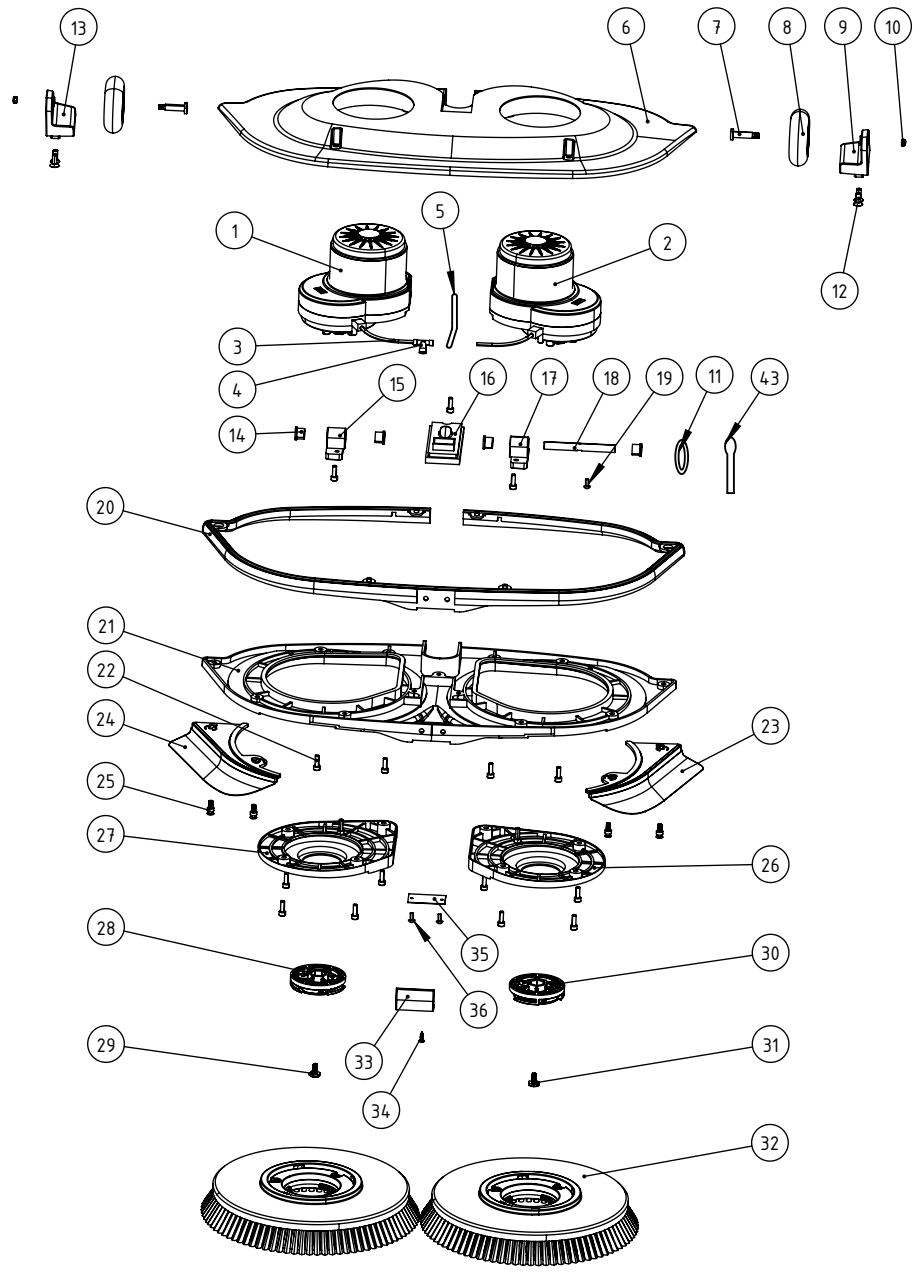

Item	P/N	Description	Qty.
	BU.IMOPXXLU.230.OU	ASSY BRUSH UNIT IMOPXXL TENNANT 24V GREY	
1	S.72.0000.12	ASSY BRUSH MOTOR RIGHT	1
2	S.72.0000.02	ASSY BRUSH MOTOR LEFT	1
3	72.0022.3	WATER CHANNEL DIA.4MM L:150mm	2
4	72.0109.0	WATER COUPLING BRUSH MOTOR	1
5	72.0022.0	WATER CHANNEL DIA.6MM L:570mm	1
6	72.1008.00	BRUSH MOTOR CONSTRUCTION COVER XXL CATEFORESE TREA	1
7	72.0027.3C	SHAFT TRANSPORT CASTOR [V3]	2
8	72.0029.2/797	[MCH211-264] (101) WHITE CASTOR + BLUE BRACKET	2
9	72.1009.00	PILLAR CASTOR XXL LEFT CATEFORESE TREATMENT	1
10	04.0048.0	NUT M5 NYLON	2
11	89.0469.2099.24	REMOVE STICKER ON THE SWITCH	2
12	72.0002.0N	NYLOK SCREW COUNTER SUNK BOLT M6X16 [MCH 1416-1001-2104]	4
13	72.1009.10	TRANSPORT WHEEL PILLAR RIGHT CATEFORESE TREATMENT	1
14	72.0016.0	BRUSHING AXIS 10 [MCH 1416-1001-2112]	4
15	72.0015.1	BRUSH UNIT HINGE SUPPORT RIGHT [MCH 1416-1001-2186]	1
16	72.0021.0	CONSTRUCTION COVER SEAL [MCH 1416-1001-2115]	1
17	72.0015.0	BRUSH UNIT HINGE SUPPORT LEFT [MCH 1416-1001-2185]	1
18	72.0013.0A	CHASSIS HINGE BELT HOLE	1
19	72.0014.0N	NYLOK SCREW COUNTER SUNK BOLT M4x12	1
20	72.1023.0	BRUSH UNIT PROTECTOR XXL	1
21	72.1110.357A	COVER, BRUSH, BOTTOM [XXL]	1
22	72.0017.0N	NYLOK SOCKET HEAD CAP SCREW M5X10	27
23	72.1571.0	SPLASH GUARD RIGHT INTEGRAL XXL	1
24	72.1570.0	SPLASH GUARD LEFT INTEGRAL XXL	1
25	72.0539.1	BOLT SPLASH GUARD M5x19 BLACK	4
26	72.0320.0	BRUSH MOTOR FIXATION PLATE RIGHT XXL	1
27	72.0319.0	BRUSH MOTOR FIXATION PLATE LEFT XXL	1
28	S.72.0637.357	CLICK-IN BRUSH DRIVING WHEEL ASSY RIGHT	1
29	72.1025.1	HEX HEAD OSD=13 BOLT M5X13 STAINLESS STEEL LEFT-HAND THREAD	1
30	S.72.0636.357	CLICK-IN BRUSH DRIVING WHEEL ASSY LEFT	1
31	72.1025.1	HEX HEAD OSD=13 BOLT M5X13 STAINLESS STEEL LEFTHAND THREAD	1
32	S.72.1092.797/797	ASS BRUSH IMOPXXL COMPLETE BLUE BRISTLE BLUE LOCKER	2
33	72.0318.0	REPLACABLE BUMPER PIECE	1
34	72.0240.1	COUNT SUNK SCREW M3.5X11 PHILPS HEAD,	1
35	89.0467.2099.04C	METAL PLATE IMOPXXL THICKNESS:0.5MM ELECTROPHORESIS	1
36	109.0083.0	SCREW ST3 X 5_Y_SLOT_FT_SU304	2
37	57.0076.0 NO SHOW	BLACK CABLE TIE 3 X 15 BLACK	1
38	72.0394.0	IMOP PEDESTAL SHAFT PIN	2

TOLERANCES UNSPECIFIED		REMARK:		<p style="text-align: center;">SMT-FCT DONGGUAN THE FRIENDLY FAMILY 东莞硕能塑胶模具有限公司 ASSEMBLY AND MOULDING OF CLEANING</p>			
LINE	ANGLE	-					
.xxx	±0.005	x	±2°				A
.xx	±0.05	.x	±1.5°				mm
.x	±0.1	.xx	±1°				UNIT
.	±0.2	.xxx	±0.5°				SCALE
xx	±0.5						1:1
xxx	±1						PROJECT
SHEET 1 OF 1		DATE		16/Jul/2024		SCALE	

1	2		3		4		5		6	
Revision	Description		Revised	Date						
A	First released version		Connie	01/Aug/2023						
A	SECOND RELEASE		YANG	16/Jul/2024						

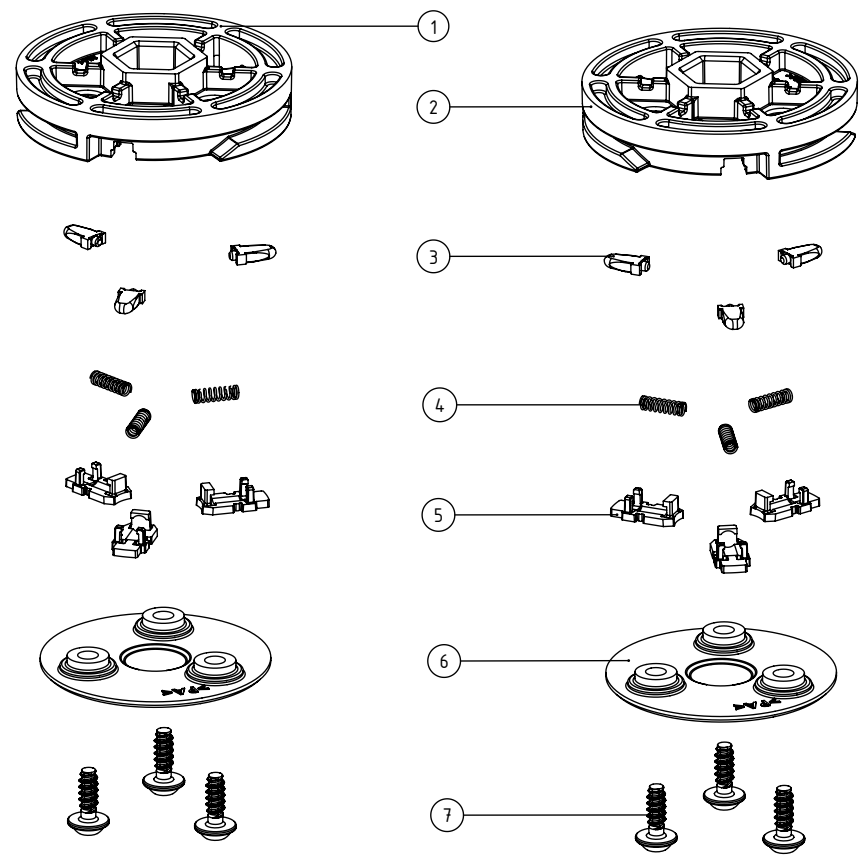

Item	P/N	Description	Qty.
	P.72.0636.357	CLICK-IN BRUSH DRIVING WHEEL ASSY LEFT+RIGHT	
1	72.0636.357	CLICK-IN BRUSH DRIVING WHEEL LEFT GREY P431C	1
2	72.0637.357	CLICK-IN BRUSH DRIVING WHEEL RIGHT GREY P431C	1
3	115.0330.357	BULB-ENDED SLIDER BRUSH LOCKER	6
4	115.0331.0	COMPRESSION SPRING OD3.7 x ID2.7 x L12	6
5	115.0329.357	SLIDER HOUSING BRUSH LOCKER	6
6	72.0638.797	CLICK-IN BRUSH DRIVING WHEEL COVER BLUE P312C	2
7	72.0026.0	SCREW WN 5451 5.0X14 EJOT DELTA PT	6

TOLERANCES AND DIMENSIONS (UNLESS OTHERWISE SPECIFIED)		MATERIAL:		 东莞顿能塑胶模具有限公司 Dongguan Solid-CST Plastic Molding Co., Ltd. 东莞市石碣镇新风西路99号 No.99 XinFeng West Road ShiJie Town DongGuan City China				
0.5-3mm	±0.1mm	COLOR:						
3-6mm	±0.1mm	TREATMENT:						
6-30mm	±0.2mm	APPROVED	CHECKED	DISGNE	REV.	R01	PART NAME	IMOPXXLU.FCT.0C EXPLODED VIEW
30-120mm	±0.3mm			YANG	UNIT	mm	PART NO	IMOPXXLU.FCT.0C
120-400mm	±0.5mm			16/Jul/2024	SCALE	1:1	PROJECT	
ANGLES	±1.0°							A4 Page 1 / 1
HOLE Ø	±0.1mm							

1		2		3		4		5		6	
Revision	Description	Revised	Date								
A	FIRST RELEASE	CONNIE	01/Aug/2023								
A	SECOND RELEASE	YANG	16/Jul/2024								
				PAGE 16 / 27							

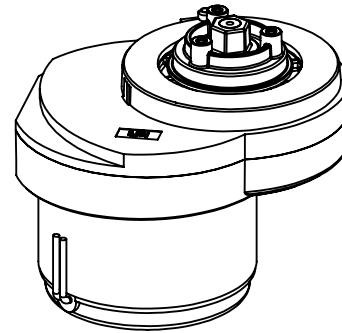
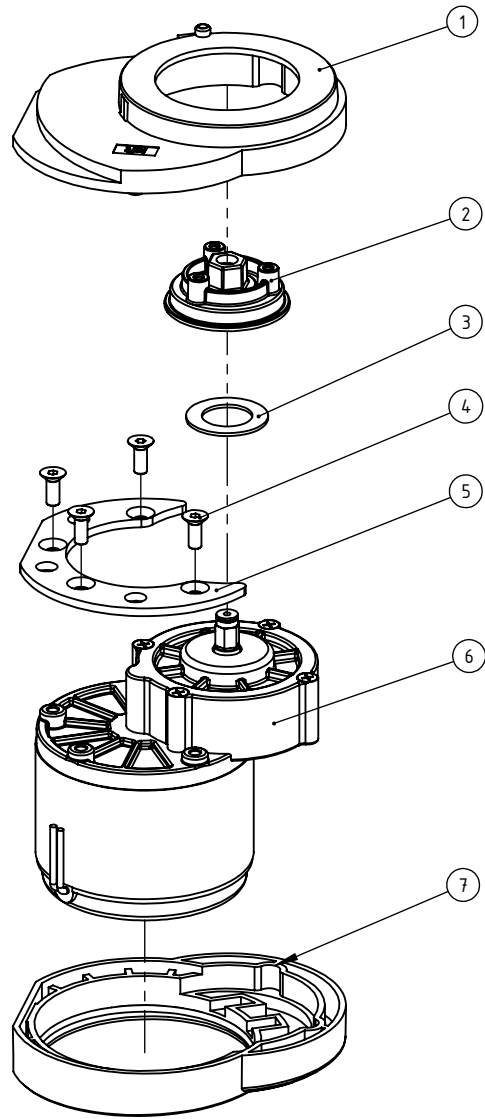

Item	P/N	Description	Qty.
	S.72.0000.02	ASSY BRUSH MOTOR LEFT	
1	72.0007.0	BRUSH MOTOR SUPPORT SUPPORT RUBBER LEFT (MCH 1416-1001-2107)	1
2	72.0005.357/C	DRIVING WHEEL TOP WITH TREAT INSERT (C)	1
3	72.0004.0	FELT BRUSH MOTOR (MCH 1416-1001-2183)	1
4	72.0002.0N	NYLOK SCREW COUNTER SUNK BOLT M6X16 [MCH 1416-100	4
5	72.0001.0	BRUSH MOTOR CONSTRUCTION RING LEFT (MCH 1416-1001-2106)	1
6	72.0000.0MR	BRUSH MOTOR HELICAL GEARS LEFT MAGNET RING	1
7	72.0006.0/A	BRUSH MOTOR FIXATION CONDUCTIVE RUBBER LEFT	1
9	89.0469.2099.00 NO SHOW	SERTAL NO. BRUSH MOTOR LEFT	1

TOLERANCES UNSPECIFIED		REMARK: -		SMT-FCT DONGGUAN THE FRIENDLY FAMILY 东莞硕能塑胶模具有限公司 ASSEMBLY AND MOULDING OF CLEANING			
LINE	ANGLE	-					
.xxx ±0.005	x ±2°	-		APPROVED	CHECKED	DISGND	REV.
.xx ±0.05	.x ±1.5°	-					A
.x ±0.1	.xx ±1°	-					PART NAME
. ±0.2	.xxx ±0.5°	-					IMOPXXLU.FCT.0C EXPLODED VIEW
xx ±0.5		-					PART NO
xxx ±1		-					IMOPXXLU.FCT.0C
SHEET OF		DATE					SCALE
		16/Jul/2024					PROJECT
							SIZE
							A4

1	2	3	4	5	6
Revision	Description	Revised	Date	PAGE 17 / 27	
A	FIRST RELEASE	CONNIE	01/Aug/2023		
A	SECOND RELEASE	YANG	16/Jul/2024		

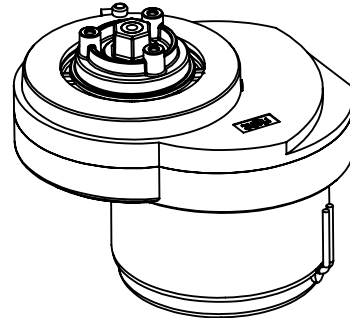
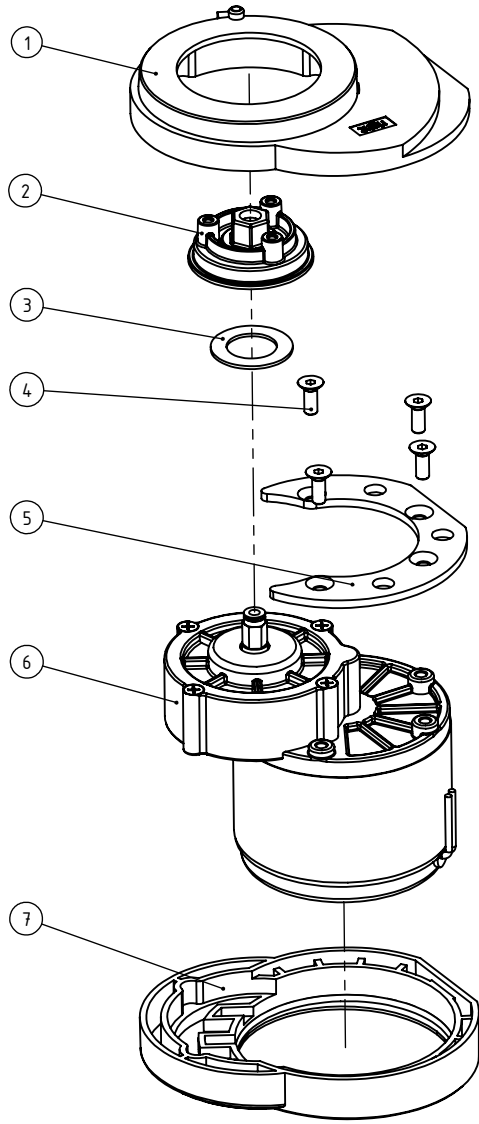

Item	P/N	Description	Qty.
	S.72.0000.12	ASSY BRUSH MOTOR RIGHT	
1	72.0007.1	BRUSH MOTOR SUPPORT RUBBER RIGHT (MCH 1416-1001-2101)	1
2	72.0005.357/C	DRIVING WHEEL TOP WITH TREAT INSERT (C)	1
3	72.0004.0	FELT BRUSH MOTOR (MCH 1416-1001-2183)	1
4	72.0002.0N	NYLOK SCREW COUNTER SUNK BOLT M6X16 (MCH 1416-1001-2104)	4
5	72.0001.1	BRUSH MOTOR CONSTRUCTION RING RIGHT (MCH 1416-1001-2007)	1
6	72.0000.1MR	BRUSH MOTOR HELICAL GEARS RIGHT MAGNET RING	1
7	72.0006.1/A	BRUSH MOTOR FIXATION CONDUCTIVE RUBBER RIGHT	1
9	89.0469.2099.01 NO SHOW	SERTAL NO. BRUSH MOTOR RIGHT	1

TOLERANCES UNSPECIFIED		REMARK: -		SMT-FCT DONGGUAN THE FRIENDLY FAMILY 东莞硕能塑胶模具有限公司 ASSEMBLY AND MOULDING OF CLEANING							
LINE	ANGLE	-						MATERIAL: -			
.xxx	±0.005	x	±2°	APPROVED	CHECKED	DISGNE	REV. A	PART NAME	IMOPXXLU.FCT.0C EXPLODED VIEW		
.xx	±0.05	.x	±1.5°			YANG	UNIT	mm	PART NO	IMOPXXLU.FCT.0C	SIZE
.x	±0.1	.xx	±1°				SCALE		PROJECT		A4
.	±0.2	.xxx	±0.5°								
xx	±0.5			SHEET OF	DATE	16/Jul/2024					
xxx	±1										

Revision	Description	Revised	Date
A	FIRST RELEASE	CONNIE	07/Aug/2023
A	SECOND RELEASE	YANG	16/Jul/2024

A
B
C
D

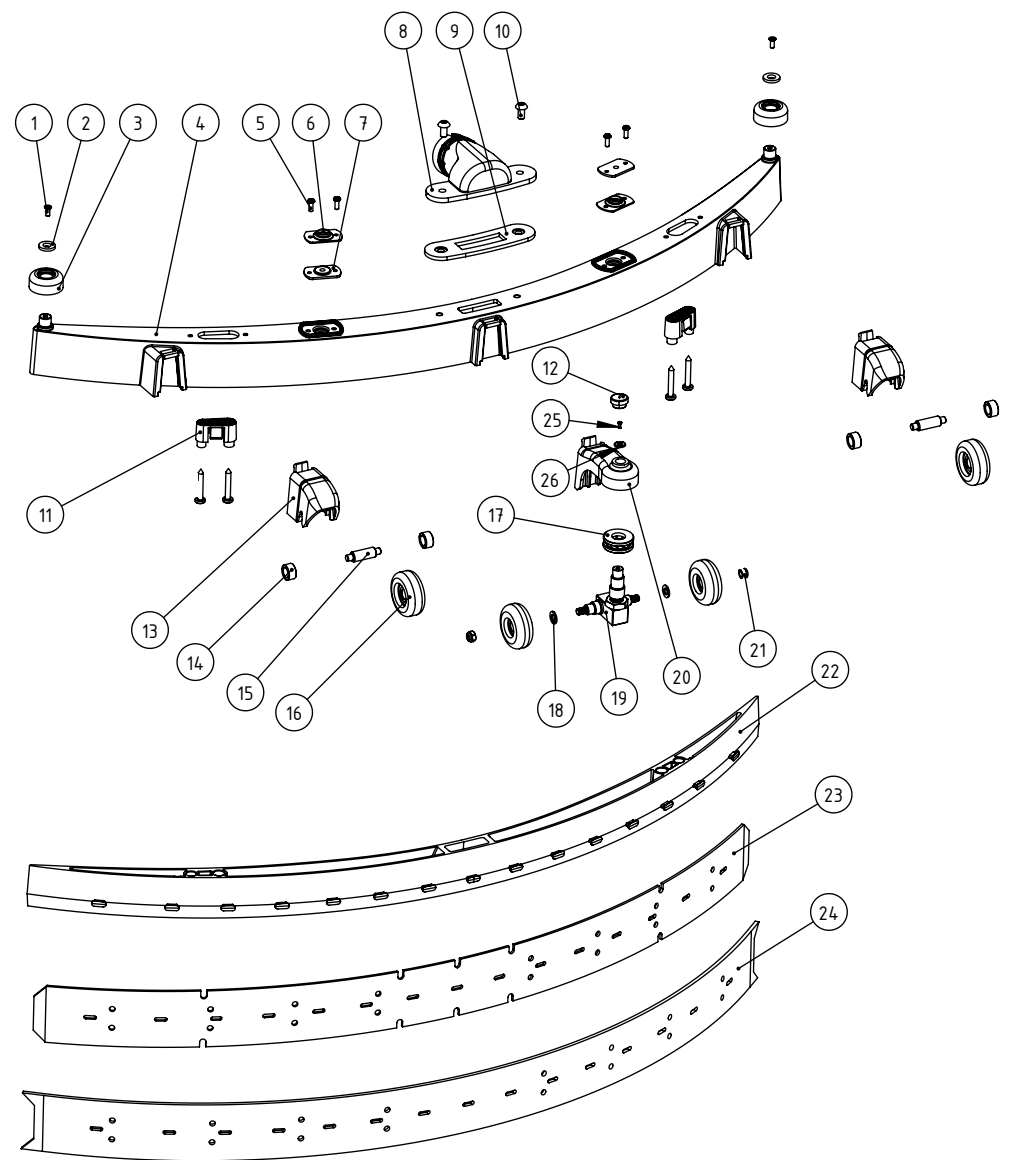

Item	P/N	Description	Qty.
	S.72.1601.21/00	PRO SQUEEGEE IMOPXXL LINATEX RABBET CATEFORESE	
1	115.0037.0	(MCH 013-109 [101] COUNTERSUNK HEAD SCREW TORX M3X8	2
2	72.0608.0	COUNTER SUNK WASHER M3 OD13.2xT2	2
3	72.0606.0	SQUEEGEE GUIDING CASTOR OD27	2
4	72.1601.00	SQUEEGEE MAIN FRAME I-MOP XXL CATEFORESE	1
5	115.0037.1	MCH-013-109-101 CYLINDER ROUND HEAD CAP SCREW M3 x 8 SUS304	4
6	72.0340.0A	FIXATION PLATE SQUEEGEE PIN STAINLESS STEEL	2
7	72.0200.0/D	RUBBER WASHER FIXATION SQUEEGEE PIN BLACK Thicknes	2
8	72.0103.8D	SQUEEGEE HOSE CONNECTOR HOOK YELLOW P122C	1
9	72.0102.0/A	SQUEEGEE HOSE CONNECTOR SEALING GASKET	1
10	115.0095.0	[MCH 013-105] (101) CYLINDER ROUND HEAD CAP SCREW M5X12	2
11	S.72.1603.8	PUSHING KNOB ASSY SQUEEGEE XL&X	2
12	72.0662.357	SQUEEGEE SWIVAL CASTOR RUBBER GASKET	1
13	72.0605.357	SQUEEGEE CASTOR BRACKET REMOVABLE STATIC	2
14	72.0607.0	STATIC CASTOR SPACER ID8.1xOD12.5xT6.6	4
15	72.0609.0	CASTOR SHAFT OD8xL30	2
16	72.0238.32	SQUEEGEE CASTOR GREY DIA.8MM	4
17	72.0613.0	THRUST BALL BEARING 51100 STAINLESS STEEL	1
18	72.0235.0	M5 WASHER STAINLESS STEEL 5X15X1MM	2
19	72.0610.0	DUAL CASTOR SHAFT ASSY	1
20	72.0604.357B	SQUEEGEE CASTOR BRACKET REMOVABLE SWIVEL	1
21	04.0048.0	NUT M5 NYLON STAINLESS	2
22	72.1602.00	SQUEEGEE RUBBER BLADE HOLDER IMOPXXL CATEFORESE	1
23	72.1655.21	SQUEEGEE RUBBER XXL FRONT LINATEX EXTENDED RABBET	1
24	72.1656.2	SQUEEGEE RUBBER XXL REAR LINATEX EXTENDED	1
25	115.0037.0	(MCH 013-109 [101] COUNTERSUNK HEAD SCREW TORX M3X8	1
26	72.0608.1	COUNTER SUNK WASHER M3 OD14.6xT2 BLACK	1

TOLERANCES UNSPECIFIED		REMARK: -		<p style="text-align: center;">SMT-FCT DONGGUAN THE FRIENDLY FAMILY 东莞硕能塑胶模具有限公司 ASSEMBLY AND MOULDING OF CLEANING</p>					
LINE	ANGLE	MATERIAL: -							
.xxx ±0.005	x ±2°	APPROVED	CHECKED	DISGNE	REV.	A	PART NAME	IMOPXXL.FCT.OC EXPLODED VIEW	
.xx ±0.05	.x ±1.5°			YANG	UNIT	mm	PART NO	IMOPXXL.FCT.OC	SIZE
.x ±0.1	.xx ±1°				SCALE	1:1	PROJECT		A4
. ±0.2	.xxx ±0.5°	SHEET 1 OF 1		DATE		16/Jul/2024			

1	2	3	4	5	6
Revision	Description	Revised	Date		PAGE 19 / 27
A	FIRST RELEASE	CONNIE	07/Aug/2023		
A	SECOND RELEASE	YANG	16/Jul/2024		

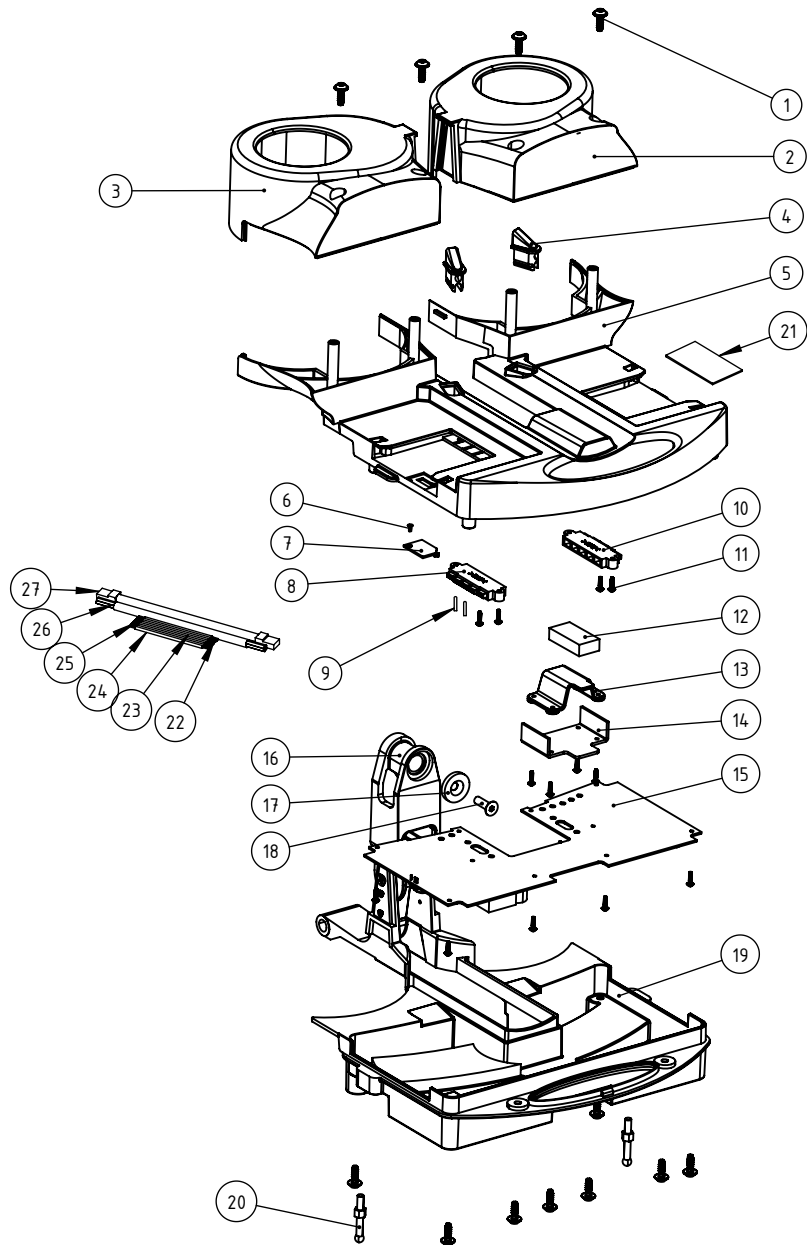

Item	P/N	Description	Qty.
	S.72.1065.1U	ASSY MAIN LEVER UNIT IMOPXXL MERCURY SWITCH CATA	
1	72.0026.0	SCREW WN 5451 5.0X14 EJOT DELTA PT	12
2	72.1072.2B	BRUSH MOTOR COOLING COVER XXL RIGHT THROUGH SHAFT	1
3	72.1073.2B	BRUSH MOTOR COOLING COVER XXL LEFT THROUGH SHAFT	1
4	72.0069.0A	PCB MACHINE SEAL	2
5	72.1065.2B	MAIN LEVER COVER XXL WHITE FOR FORTIFIED MAIN LEV	1
6	72.0165.0	SCREW COUNTSUNK M1.7X6	2
7	72.0164.2	COVER USB UPDATE SLOT, Kleur: White .2	1
8	72.0068.357	BATTERY CONNECTOR MALE Left:Blue Right:Grey, Kle	1
9	85.0050.1A	ALIGNMENT PIN Ø1.5x7 STAINLESS STEEL	4
10	72.0068.357	BATTERY CONNECTOR MALE Left:Blue Right:Grey, Kle	1
11	72.0057.0	[MCH011-101-101] SCREW WN 5451 25X10 EJOT DELTA PT	18
12	72.0051.0	MAGNET TOP UNIT 40X20X10mm (MCH 1416-1001-2044)	1
13	72.0067.357	MAGNET TOP UNIT HOLDER [MCH 1416-1001-2192], Kleur	1
14	72.0219.0	STEEL COVER ISOLATION MAGNETIC T=3mm	1
15	72.0652.0	MAIN PCB IMOP WITH GYROSCOPE 30MINUTES ALRMING TWO SPEED	1
16	S.72.0018.10S	ASSY HINGE CARDAN CATEFORESE TREATMENT ZINC ALLOY	1
17	72.0058.1	CARDAN DISK [Ver1]	1
18	72.0033.2	COUNTER SUNK HEAD CAP SCREW M6X20 WITH NYLOK SCREW	1
19	72.0010.10A	MAIN LEVER HOUSING THRU. SHAFT CATEFORESE TREATMENT TOOLSENSE	1
20	72.1071.0	SQUEEGEE FIXATION PIN XXL	2
21	89.0467.2099.10	STICKER IMOP [STRONG MAGNETS] [B]	1
22	72.0123.0A	MONOLITHIC MALE CONNECTOR + WIRES 14AWG RED 120MM	2
23	72.0124.0A	MONOLITHIC MALE CONNECTOR + CONNECTOR WIRES 14AWGBLACK 120MM	2
24	72.0157.0/A	WIRES FOR BRUSH UNIT 14AWG BLACK ANGLE TERMINAL L=280mm	2
25	72.0157.1/A	WIRES FOR BRUSH UNIT 14AWG RED ANGLE TERMINAL L=280mm	2
26	S.72.0126.3	ASSY POWER CABLE 4 WIRES ANGLE TERMINALS [1.5MM 2 L=630MM]	1
27	S.72.0125.3	ASSY UTP CABLE (GLASS+FIBRE) 10P AVIATION PLUG + SEALING RING I-LINK	1
28	72.0222.0 NO SHOW	PET SHEET ONE SIDE 3M GLUE T=0.04MM	4

TOLERANCES UNSPECIFIED		REMARK:		SMT-FCT DONGGUAN THE FRIENDLY FAMILY 东莞硕能塑胶模具有限公司 ASSEMBLY AND MOULDING OF CLEANING			
LINE	ANGLE	-					
.xxx ±0.005	x ±2°	MATERIAL: -		APPROVED	CHECKED	DISGNE	REV.
.xx ±0.05	.x ±1.5°					YANG	A
.x ±0.1	.xx ±1°						UNIT
. ±0.2	.xxx ±0.5°						mm
xx ±0.5							PART NAME
xxx ±1							IMOPXXLU.FCT.0C EXPLODED VIEW
SHEET 1 OF 1		DATE					PART NO
		16/Jul/2024					IMOPXXLU.FCT.0C
		SCALE					SIZE
							A4

1	2		3		4		5		6	
Revision	Description		Revised	Date					PAGE	20 / 27
A	First released version		Connie	01/Aug/2023						
A	SECOND RELEASE		YANG	16/Jul/2024						

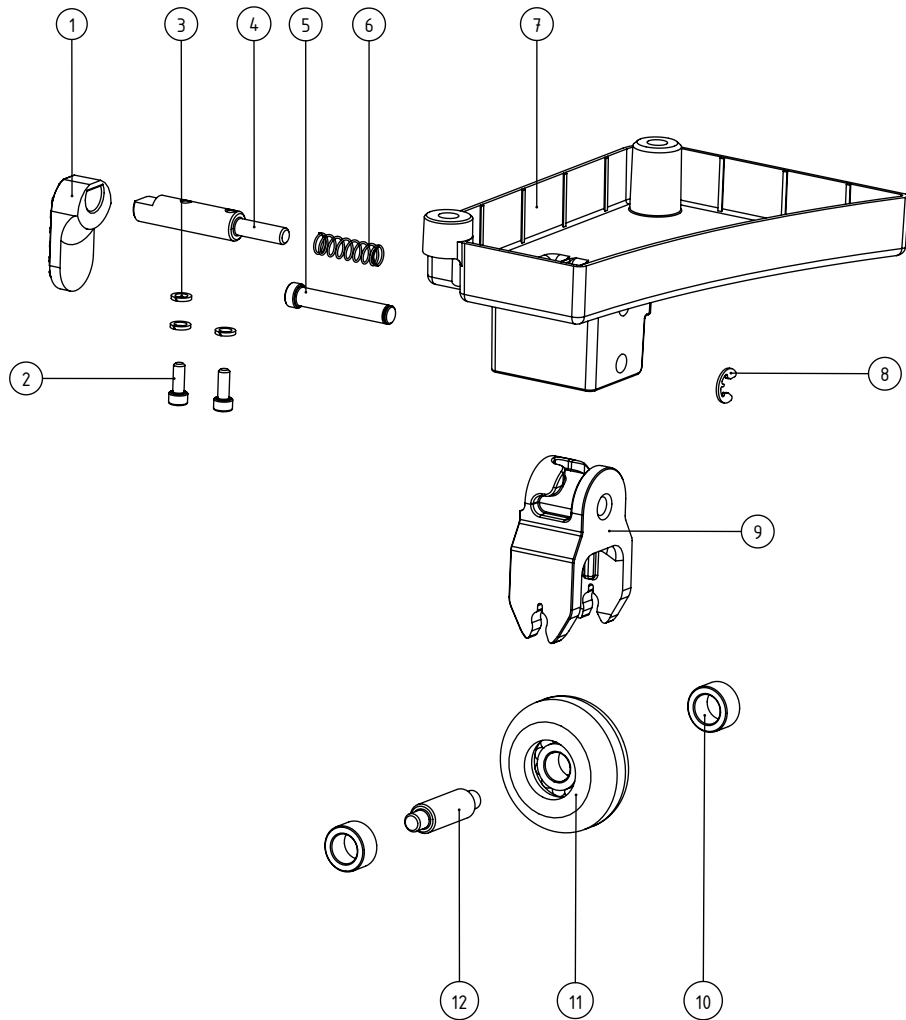

Item	P/N	Description	Qty.
	S.72.0643.357	DECK FOLDABLE CASTOR DOUBLE SCRUBBING ASSY	
1	72.0648.8	PUSH BUTTON LOCKING SHAFT	1
2	124.0029.0	HEX SOCKET SCREW M3X8 GB/T 70.1 HEAD OD 4.90-5.15MM STAINLESS STEEL	2
3	24.0054.0	M3 SPRING WASHER	3
4	72.0647.0	LOCKING SHAFT	1
5	72.0646.0	CASTOR BRACKET PIVOT	1
6	119.0096.0A	SPRING 19.2X5.7X0.5MM	1
7	72.0643.357	DECK FOLDABLE CASTOR BASE DOUBLE SCRUBBING	1
8	115.0303.0	[MCH 031-101](101) CIRCLIP EXTERNAL 4.0 GB/T 896-1986	1
9	72.0644.357	CASTOR BRACKET FOLDABLE	1
10	72.0607.0	STATIC CASTOR SPACER ID8.1xOD12.5xT6.6	2
11	72.0238.32	SQEEGEE CASTOR GREY DIA.8MM	1
12	72.0609.0	CASTOR SHAFT OD8xL30	1

TOLERANCES AND DIMENSIONS (UNLESS OTHERWISE SPECIFIED)		MATERIAL:		 东莞顿能塑胶模具有限公司 Dongguan Solid-CST Plastic Molding Co., Ltd 东莞市石碣镇新风西路99号 No.99 XinFeng West Road ShiJie Town DongGuan City China				
0.5-3mm	±0.1mm	COLOR:						
3-6mm	±0.1mm	TREATMENT:						
6-30mm	±0.2mm	APPROVED	CHECKED	DISGNE	REV.	R01	PART NAME	IMOPXXLU.FCT.0C EXPLODED VIEW
30-120mm	±0.3mm			YANG	UNIT	mm	PART NO	IMOPXXLU.FCT.0C
120-400mm	±0.5mm				SCALE	1:1	PROJECT	
ANGLES	±1.0°			16/Jul/2024				
HOLE Ø	±0.1mm							

1	2		3		4		5		6	
Revision	Description		Revised	Date					PAGE	21 / 27
A	First released version		Connie	01/Aug/2023						
A	SECOND RELEASE		YANG	16/Jul/2024						

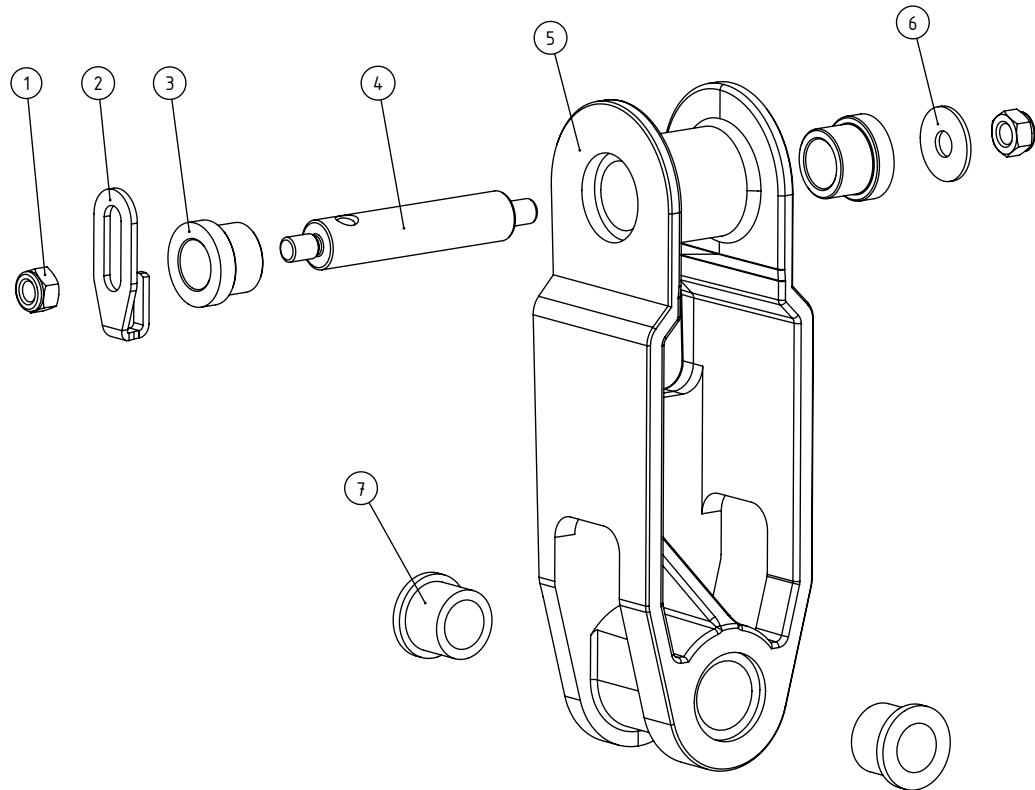

Item	P/N	Description	Qty.
	S.72.0018.10S	ASSY HINGE CARDAN CATEFORESE TREATMENT ZINC ALLOY	
1	04.0048.0	NUT M5 NYLON STAINLESS	2
2	72.0533.0	HINGE SHAFT FIXING PLATE	1
3	72.0532.0	HINGE PLASTIC BEARING ID 10	2
4	72.0019.1	HINGE SHAFT OD10 THROUGH	1
5	72.0018.00S	HINGE CARDAN TOP UNIT CATEFORESE TREATMENT ZINC ALLOY	1
6	72.0235.0	M5 WASHER STAINLESS STEEL 5X15X1MM	1
7	72.0016.0	BRUSHING AXIS 10 [MCH 1416-1001-2112]	2

TOLERANCES AND DIMENSIONS (UNLESS OTHERWISE SPECIFIED)		MATERIAL:						
0.5-3mm	±0.1mm	COLOR:						
3-6mm	±0.1mm	TREATMENT:						
6-30mm	±0.2mm	APPROVED	CHECKED	DISGNE	REV.	R01	PART NAME	IMOPXXLU.FCT.0C EXPLODED VIEW
30-120mm	±0.3mm			YANG	UNIT	mm	PART NO	IMOPXXLU.FCT.0C
120-400mm	±0.5mm			16/Jul/2024	SCALE	1:1	PROJECT	
ANGLES	±1.0°							A4 Page 1 / 1
HOLE Ø	±0.1mm							

Revision	Description	Revised	Date
A	FIRST RELEASE	CONNIE	01/Aug/2023
A	SECOND RELEASE	YANG	16/Jul/2024

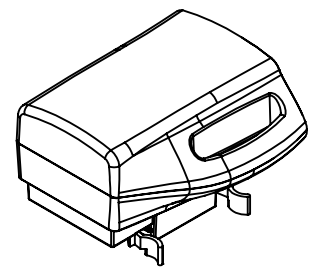
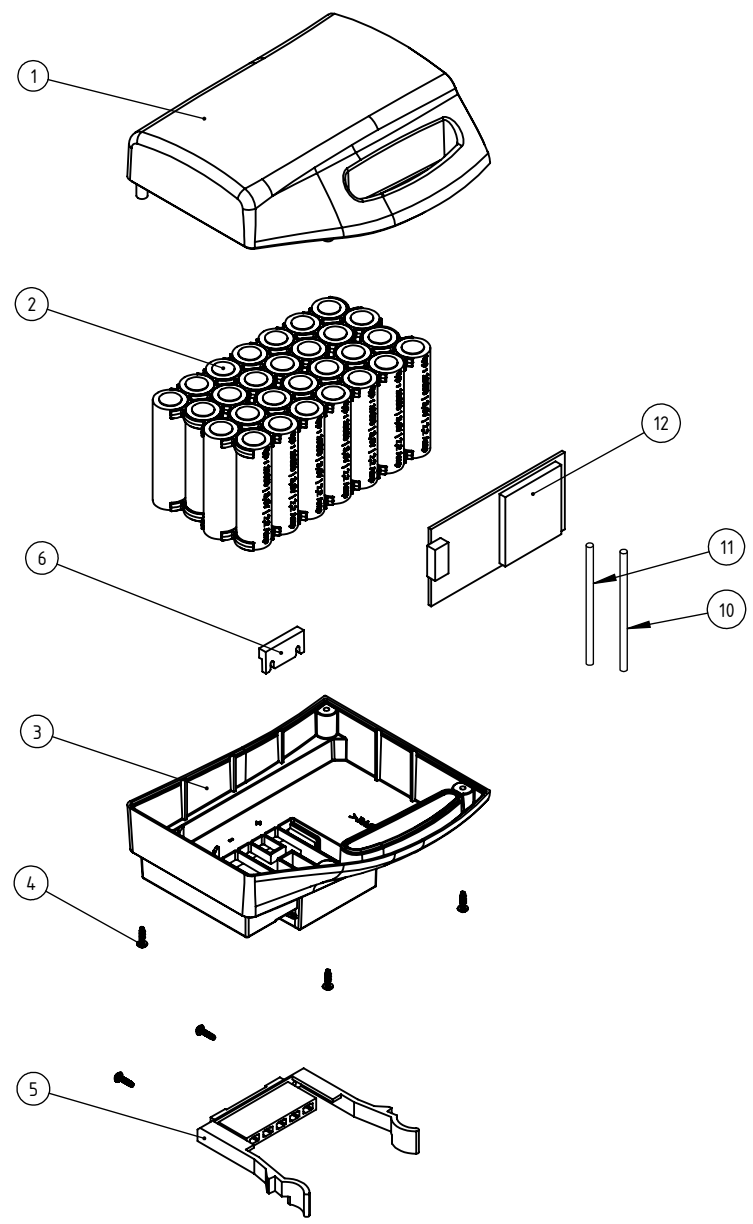

Item	P/N	Description	Qty.
	S.72.0079.357BSRA	ASSY BATTERY PACK GREY [RIGHT] BMS 14Ah [FR][W/OF]	
1	72.0132.357R	BATTERY PACK HOUSING TOP RIGHT [FIRE RESISTAN	1
2	72.0131.1/C	BATTERY PACK CELLS WITH BMS [14Ah][W/O FUSE]	1
3	72.0079.357R	BATTERY PACK HOUSING BOTTOM RIGHT [FR]	1
4	72.0057.0	(MCH 011-101-101)SCREW WN 5451 25X10 EJOT DELATA PT	6
5	72.1075.357	BATTERY CONNECTOR WITH DOWEL PIN HOLES FEMALE GREY [RIGHT]	1
6	72.0218.0	LIMITATION BLOCK FEMALE CONNECTOR	1
7	72.0170.0 NO SHOW	BUBBLE WRAP BAG 250x210	1
8	89.0469.2099.05 NO SHOW	SERIAL NO. BATTERY[C]	1
9	89.0469.2099.07BM NO SHOW	STICKER SAFETY ADVISE FOR BATTERY RIGHT BMS	1
10	72.0129.0A	BATTERY CONNECTOR + WIRES 14AWG, RED, L=290mm TYCO TERMINAL 964328-1	1
11	72.0130.0A	BATTERY CONNECTOR + WIRES 14AWG, BLACK, L=320mm TYCO TERMINAL 964328-1	1
12	72.0284.0A	BMS BOARD I-POWER 9&14 SUPPLIER MODEL 7SZYJH-D120	1

TOLERANCES UNSPECIFIED		REMARK:		SMT=FCT DONGGUAN THE FRIENDLY FAMILY 东莞硕能塑胶模具有限公司 ASSEMBLY AND MOULDING OF CLEANING							
LINE	ANGLE	-		MATERIAL: -							
.xxx	±0.005	x	±2°	APPROVED	CHECKED	DISGNE	REV. A	PART NAME	IMOPXXLU.FCT.0C EXPLODED VIEW	SIZE	
.xx	±0.05	.x	±1.5°			YANG	UNIT	PART NO	IMOPXXLU.FCT.0C	A4	
.x	±0.1	.xx	±1°				SCALE	PROJECT			
.	±0.2	.xxx	±0.5°								
xx	±0.5										
xxx	±1										
SHEET OF		DATE		16/Jul/2024		SCALE		1:1		PROJECT	

Revision		Description		Revised	Date	PAGE		23 / 27	
A		FIRST RELEASE		CONNIE	01/Aug/2023				
A		SECOND RELEASE		YANG	16/Jul/2024				

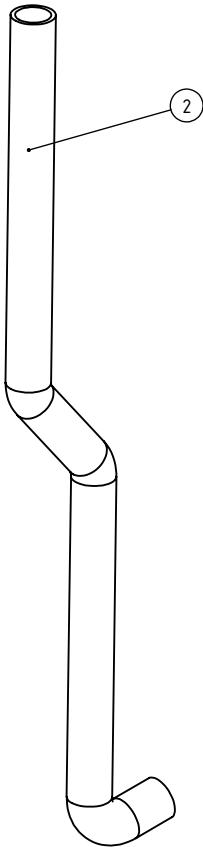

Item	P/N	Description	Qty.
	S.72.1094.0	STRETCH HOSE COMPLETE	
1	72.1095.8	STRETCH HOSE CUFF WITH HOOK YELLOW	2
2	72.0094.0	STRETCH HOSE TOP UNIT [MCH 1416-1001-2098]	1
3			

TOLERANCES UNSPECIFIED		REMARK: -		 东莞硕能塑胶模具有限公司 ASSEMBLY AND MOULDING OF CLEANING					
LINE	ANGLE	MATERIAL: -							
.xxx ±0.005	x ±2°	APPROVED	CHECKED	DISGNE	REV.	A	PART NAME	IMOPXXLU.FCT.0C EXPLODED VIEW	
.xx ±0.05	.x ±1.5°			YANG	UNIT	mm	PART NO	IMOPXXLU.FCT.0C	SIZE
.x ±0.1	.xx ±1°				SCALE		PROJECT		A4
. ±0.2	.xxx ±0.5°								
xx ±0.5									
xxx ±1									
SHEET 1 OF 1		DATE		16/Jul/2024					

Revision	Description	Revised	Date
A	FIRST RELEASE	CONNIE	01/Aug/2023
A	SECOND RELEASE	YANG	16/Jul/2024

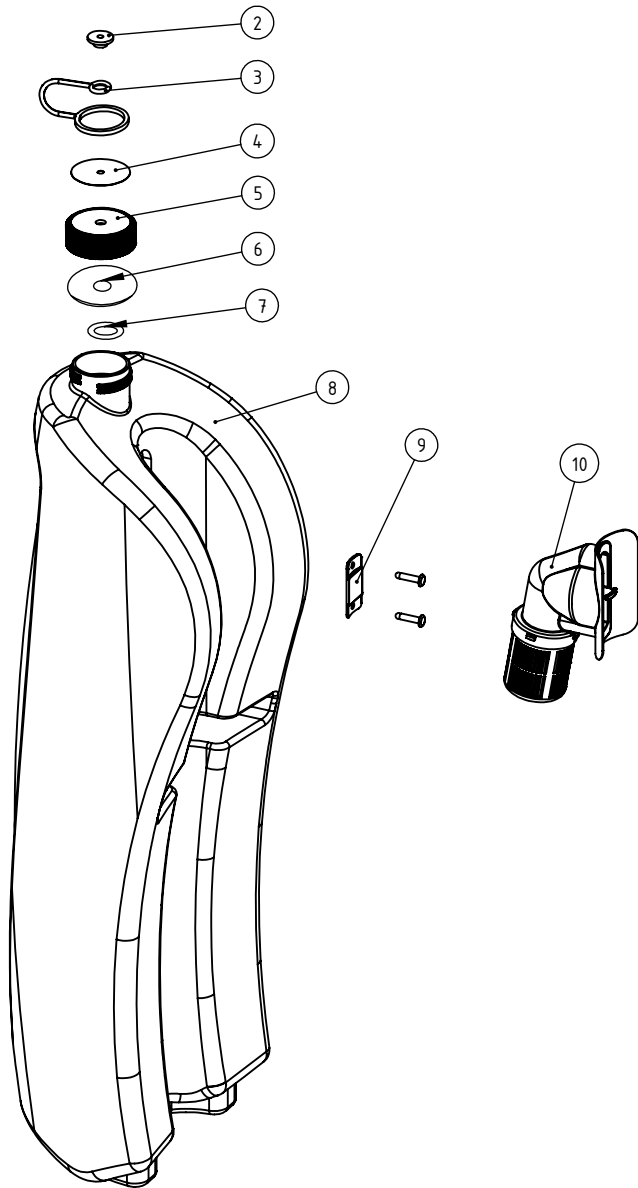

Item	P/N	Description	Qty.
	S.72.1088.4F	DIRT COMPARTMENT XXL FLOAT BALL ANTIBACTERIAL	
1	54.0029.0	BLIND REVIT NAIL 4X15mmg	3
2	72.0254.0	SLEEVE CAP HOLDER	1
3	72.0252.1	CAP HOLDER CANVAS FILLED RUBBER	1
4	89.0469.2099.25A	WARNING PLATE ON DIRTY TANK ROUND STAINLESS PLATE	1
5	72.0264.357	CAP WITHOUT HOLE COLOR: GREY (P431C)	1
6	72.0265.0	SEALING GASKET CAP DIRTY TANK	1
7	72.0271.0	PLASTIC WASHER 9x4x1mm	1
8	72.1088.4	RECOVERY COMPARTMENT XXL ANTIBACTERIAL	1
9	72.0089.1	STEEL PLATE FOR RECOVERY TANK	1
10	S.72.0407.797	ASSY FLOAT BALL	1

TOLERANCES UNSPECIFIED		REMARK:		SMT-FCT DONGGUAN THE FRIENDLY FAMILY 东莞硕能塑胶模具有限公司 ASSEMBLY AND MOULDING OF CLEANING			
LINE	ANGLE	-		FIRST ANGLE PROJECTION			
.xxx	±0.005	x	±2°	APPROVED	CHECKED	DISGNE	REV.
.xx	±0.05	.x	±1.5°				A
.x	±0.1	.xx	±1°	MATERIAL: -			
.	±0.2	.xxx	±0.5°			YANG	UNIT
xx	±0.5					UNIT	mm
xxx	±1					SCALE	1:1
SHEET OF		DATE		16/Jul/2024		SCALE	
				SCALE		PROJECT	

Revision	Description	Revised	Date
A	FIRST RELEASE	CONNIE	01/Aug/2023
A	SECOND RELEASE	YANG	16/Jul/2024

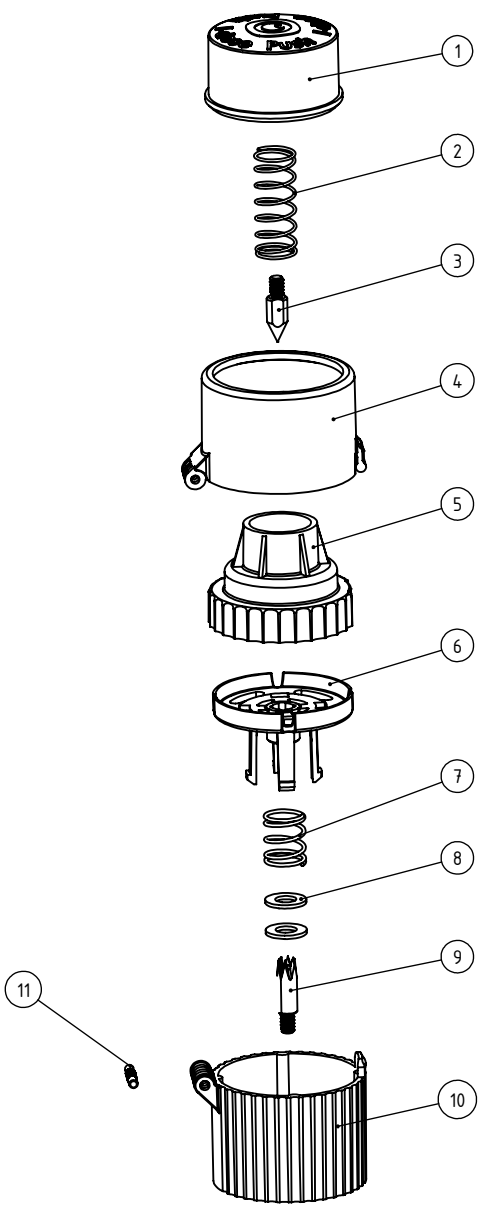

Item	P/N	Description	Qty.
	S.72.0433.0	ASSY I-DOSE INJECTOR HOUSING	
1	72.0440.0	I-DOSE PUSH BUTTON	1
2	72.0442.0	I-DOSE SPRING UPPER	1
3	72.0441.0	I-DOSE PUNCH UPPER	1
4	72.0438.0	DOSING COVER HOUSING	1
5	72.0439.0	DOSING COVER BRACKET	1
6	72.0435.0	DOSING BASE TRAY	1
7	72.0437.0	I-DOSE SPRING BOTTOM	1
8	00.0106.2	WASHER 12X6.5X1.4MM STAINLESS STEEL	2
9	72.0434.0	I-DOSE PUNCH BOTTOM	1
10	72.0433.0	I-DOSE INJECTOR BASE HOUSING	1
11	72.0443.0	I-DOSE INJETOR PIVOT	1

TOLERANCES UNSPECIFIED		REMARK:		SMT-FCT DONGGUAN							
LINE	ANGLE			THE FRIENDLY FAMILY							
.xxx	±0.005	x	±2°	东莞硕能塑胶模具有限公司 ASSEMBLY AND MOULDING OF CLEANING							
.xx	±0.05	.x	±1.5°								
.x	±0.1	.xx	±1°								
.	±0.2	.xxx	±0.5°								
xx	±0.5										
xxx	±1			APPROVED	CHECKED	DISGNE	REV.	A	PART NAME	IMOPXXLU.FCT.0C EXPLODED VIEW	
						YANG	UNIT	mm	PART NO	IMOPXXLU.FCT.0C	SIZE
SHEET OF		DATE				16/Jul/2024	SCALE	PROJECT		A4	

Revision	Description	Revised	Date
A	FIRST RELEASE	Connie	01/Aug/2023
A	SECOND RELEASE	YANG	16/Jul/2024

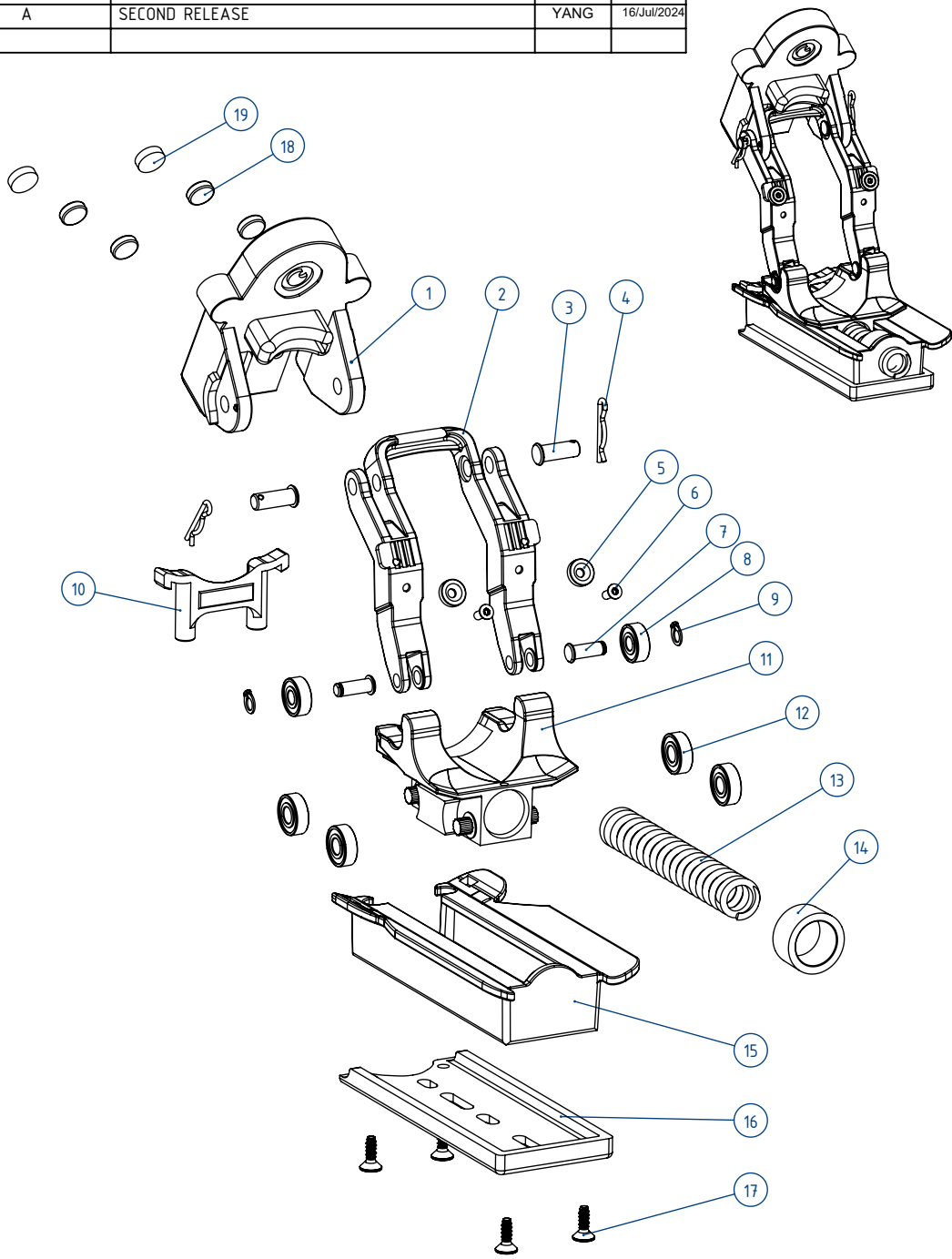

Item	P/N	Description	Qty.
	P.72.0583.797	I-BALANCE ASSEMBLY	
	S.72.0583.797	I-BALANCE REAR SUPPORT ASSY	
1	72.0583.357	I-BALANCE HINGE BUCKLE	1
2	72.0585.797	I-BALANCE HINGE FORK SUPPORT BLUE	1
3	72.0584.357	HINGE PIN Ø6x15.7	2
4	72.0474.0	R SPRING PIN Ø1.5x30	2
5	72.0621.0	GASKET SUS430	2
6	72.0012.1N	NYLOK COUNTER SUNK BOLT M3X7, SST	2
7	72.0586.357	HINGE PIN Ø5x13.7	2
8	72.0593.0	BALL BEARING 605-2RS STAINLESS STEEL 5x14x5	2
9	115.0303.0	[MCH 031-101](101) CIRCLIP EXTERNAL 4.0 GB/T 896-1986	2
10	72.0590.357	I-BALANCE SLIDER BASE FIXING BLOCK	1
11	72.0587.357	I-BALANCE SLIDER	1
12	72.0592.0	BALL BEARING 696-2RS STAINLESS STEEL 6x15x5	4
13	72.0580.0	COMPRESSION SPRING OD15.3xØ2.5xL95.3	1
14	72.0579.357	COMPRESSION SPRING SPACER ID16.5xOD23.1xT12.5	1
15	72.0588.357	I-BALANCE SLIDER BASE	1
16	72.0589.357	I-BALANCE SLIDER BASE FIXING PLATE	1
17	72.0594.0	COUNTER-SUNK SELF-TAPPLING SCREW 3.5X20 GB/T846	4
18	72.0475.0	MAGNET Ø10X3	4
19	72.0622.0	RUBBER SEAL FOR MAGNET Ø10X3	2

TOLERANCES AND DIMENSIONS (UNLESS OTHERWISE SPECIFIED)		MATERIAL:		 东莞硕能塑胶模具有限公司 Dongguan Solid-CST Plastic Molding Co., Ltd 东莞市石碣镇新风西路99号 No.99 XinFeng West Road ShiJie Town DongGuan City China				
0.5-3mm	±0.1mm	COLOR:						
3-6mm	±0.1mm	TREATMENT:						
6-30mm	±0.2mm	APPROVED	CHECKED	DISGNED	REV.	-	PART NAME	IMOPXXLU.FCT.0C EXPLODED VIEW
30-120mm	±0.3mm			YANG	UNIT	mm	PART NO	IMOPXXLU.FCT.0C
120-400mm	±0.5mm						PROJECT	
ANGLES	±1.0°			16/Jul/2024	SCALE	1:1		
HOLE Ø	±0.1mm							

A
B
C
D

A
B
C
D

Revision	Description	Revised	Date
A	FIRST RELEASE	Connie	01/Aug/2023
A	SECOND RELEASE	YANG	16/Jul/2024

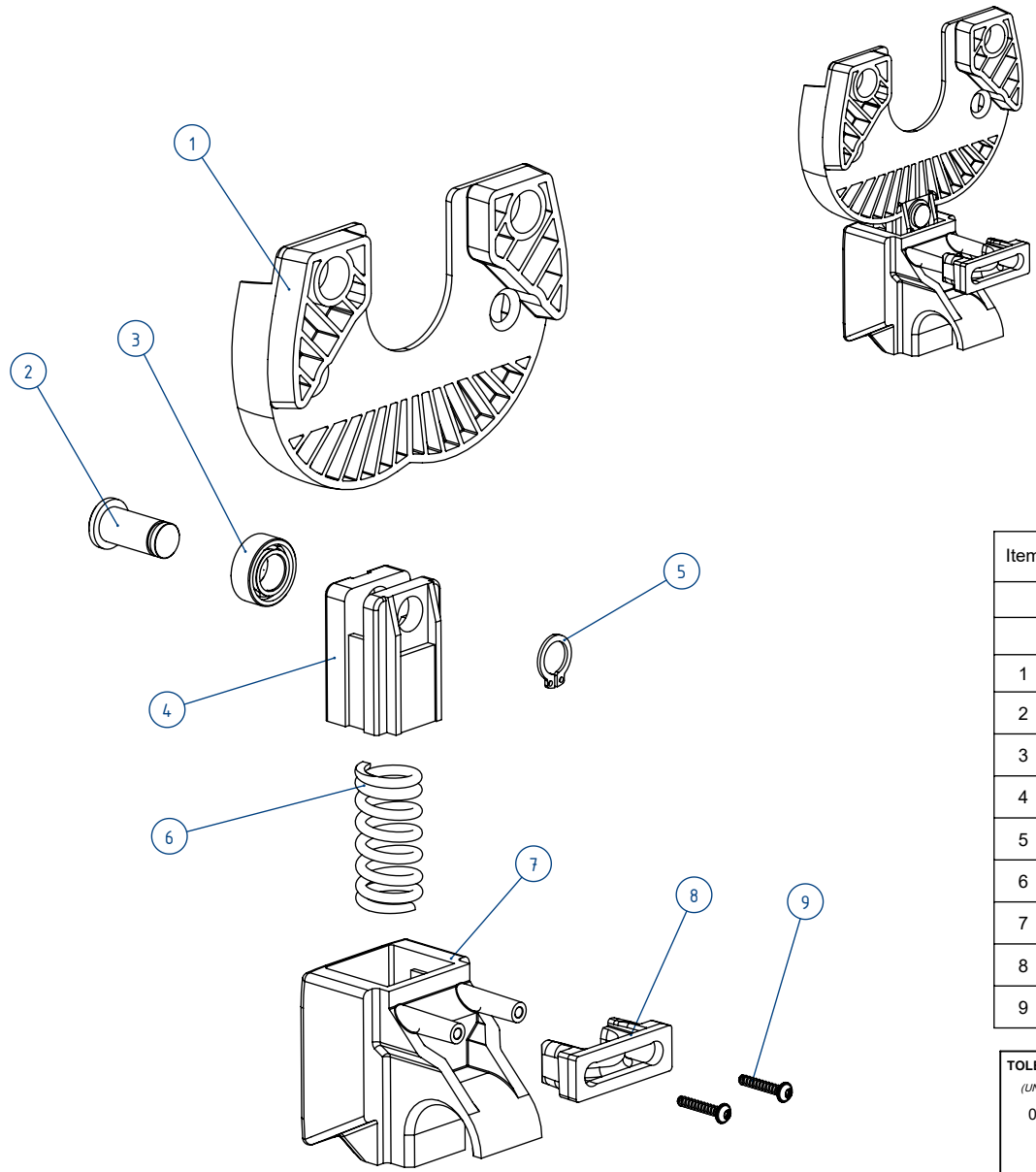

Item	P/N	Description	Qty.
	P.72.0583.797	I-BALANCE ASSEMBLY	
	S.72.0595.357	I-BALANCE CAM	
1	72.0595.357	I-BALANCE CAM	1
2	72.0598.357	HINGE PIN Ø10x21	1
3	72.0599.0	BALL BEARING 62800-2RS STAINLESS STEEL 10x19x6	1
4	72.0597.357	I-BALANCE FOLLOWER SLIDER	1
5	115.0186.0	[MCH 211-031-101] CIRCLIP EXTERNAL 10.0	1
6	72.0581.0	COMPRESSION SPRING OD19xØ4xL38	1
7	72.0596.357	I-BALANCE FOLLOWER BASE	1
8	72.0600.357	I-BALANCE FOLLOWER BASE LOCKER	1
9	115.0184.1	EJOT PT SCREW WN 5452 30X25	2

TOLERANCES AND DIMENSIONS (UNLESS OTHERWISE SPECIFIED) 0.5-3mm ±0.1mm 3-6mm ±0.1mm 6-30mm ±0.2mm 30-120mm ±0.3mm 120-400mm ±0.5mm ANGLES ±1.0° HOLE Ø ±0.1mm	MATERIAL:		SMT-FCT DONG GUAN THE FRIENDLY FAMILY 东莞顿能塑胶模具有限公司 Dongguan Solid-CST Plastic Molding Co., Ltd 东莞市石碣镇新风西路99号 No.99 XinFeng West Road ShiJie Town DongGuan City China			
	COLOR:					
	TREATMENT:					
APPROVED	CHECKED	DISGNE	REV.	-	PART NAME	IMOPXXLU.FCT.0C EXPLODED VIEW
		YANG	UNIT	mm	PART NO	IMOPXXLU.FCT.0C
		16/Jul/2024	SCALE	1:1	PROJECT	